

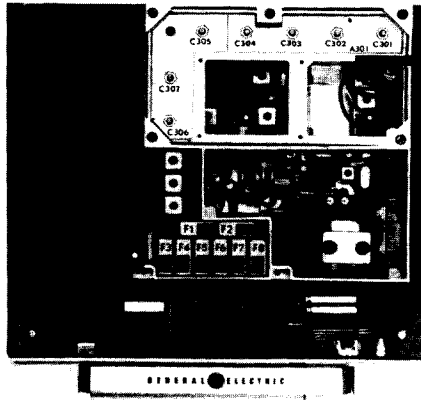

MASTR II MAINTENANCE MANUAL

138-174 MHz RECEIVER



SPECIFICATIONS *

Audio Output (to 8-ohm Speaker)

12 Watts at less than 3% distortion

Sensitivity

Standard Receiver	Ultra-High Sensitivity Receiver
-------------------	---------------------------------

12-dB SINAD (EIA Method)
20-dB Quieting Method

0.35 μ V
0.50 μ V

0.175 μ V
0.25 μ V

SELECTIVITY

EIA Two-Signal Method
20-dB Quieting Method

-100 dB
-100 dB

-95 dB

Spurious Response

-100 dB

-90 dB

Intermodulation (EIA)

-85 dB

-80 dB

Frequency Stability

5C-ICOM with EC-ICOM
5C-ICOM or EC-ICOM
2C-ICOMS

\pm 0.0005% (-40°C to +70°C)
 \pm 0.0002% (0°C to +55°C)
 \pm 0.0002% (-40°C to +70°C)

Modulation Acceptance

\pm 7 kHz (narrow-band)

Squelch Sensitivity

Critical Squelch
Maximum Squelch

0.2 μ V
Greater than 20 dB quieting (less than 1.5 μ V)

Maximum Frequency Separation
(Multi-Frequency Units)

Full Specifications	3 dB Degradation
---------------------	------------------

138-155 MHz
150.8-174 MHz

.900 MHz
1.0 MHz

1.60 MHz
1.80 MHz

Frequency Response

Within +1 and -8 dB of a standard 6-dB per octave de-emphasis curve from 300 to 3000 Hz (1000-Hz reference)

RF Input Impedance

50 ohms

* These specifications are intended primarily for the use of the serviceman. Refer to the appropriate Specification Sheet for the complete specifications.

TABLE OF CONTENTS

SPECIFICATIONS	Cover
DESCRIPTION.....	1
CIRCUIT ANALYSIS.....	1
RF Assembly.....	1
UHS Pre-amplifier.....	1
Antenna Input A301.....	2
Oscillator/Multiplier Board.....	2
ICOMs.....	2
Multiplier and Amplifier.....	4
Mixer/IF Board.....	4
Mixer and Crystal Filter.....	4
IF Amplifier.....	4
IF-Audio & Squelch Board.....	4
Crystal Filters, IF AMP and Limiter.....	4
Discriminator and Audio Pre-Amp.....	4
Audio IC.....	5
Squelch IC.....	5
MAINTENANCE.....	6
Disassembly.....	6
Alignment Procedure.....	7
Test Procedures.....	8
Receiver Troubleshooting.....	9
OUTLINE DIAGRAM.....	10
SCHEMATIC DIAGRAMS	
RF assembly, Osc/Mult & Mixer/IF Boards.....	12
IF Audio & Squelch Board.....	13
PARTS LIST AND PRODUCTION CHANGES	
RF Assembly, Osc/Mult & Mixer/IF Boards.....	11
IF Audio & Squelch Board.....	14
MODIFICATION INSTRUCTION	15

ILLUSTRATIONS

Figure 1 - Block Diagram.....	1
Figure 2 - Typical Crystal Characteristics.....	2
Figure 3 - Equivalent ICOM Circuit.....	3
Figure 4 - Disassembly Procedure (Top View).....	6
Figure 5 - Disassembly Procedure (Bottom View).....	6
Figure 6 - Test Set-Up.....	7
Figure 7 - Frequency Characteristics Vs. Temperature.....	7

WARNING

Although the highest DC voltage in MASTR II Mobile Equipment is supplied by the vehicle battery, high currents may be drawn under short circuit conditions. These currents can possibly heat metal objects such as tools, rings, watchbands, etc., enough to cause burns. Be careful when working near energized circuits! High-level RF energy in the transmitter Power Amplifier assembly can cause RF burns upon contact. Keep away from these circuits when the transmitter is energized!

DESCRIPTION

MASTR II, 138 to 174 megahertz receivers are single conversion, superheterodyne FM receivers designed for one- through eight-frequency operation. The solid state receiver utilizes integrated circuits (ICs), monolithic crystal filters and discrete components with each of the crystal filters located between gain stages to provide 100 dB selectivity and maximum protection from de-sensitization and intermodulation.

The receiver consists of the following modules:

- RF Assembly
- Mixer/IF (MIF)
- Oscillator/Multiplier (Osc/Mult)
- IF/Audio and Squelch (IFAS)
- Optional Ultra-High Sensitivity (UHS) Pre-Amplifier

Audio, supply voltages and control functions are connected to the system board through P903 on the Osc/Mult board, and

P904 on the IFAS board. The regulated +10 Volts is used for all receiver stages except the audio PA stage which operates from the A+ system supply.

Centralized metering jack J601 on the IFAS board is provided for use with GE test Set 4EX3A11 or Test Kit 4EX8K12. The test set meters the oscillator, multiplier, discriminator and IF amplifier stages. Speaker high and low are metered on the system board metering jack.

CIRCUIT ANALYSIS

RF ASSEMBLY

PRE-AMPLIFIER

The pre-amplifier is present only in UHS receivers, and uses a dual-gate Field Effect Transistor (FET) to provide approximately 12 dB gain.

RF from the antenna is coupled through T2301 to Gate 1 of pre-amplifier Q2301. The primary of T2301 provides a 50-ohm input impedance. The amplified output at the drain terminal of Q2301 is coupled through

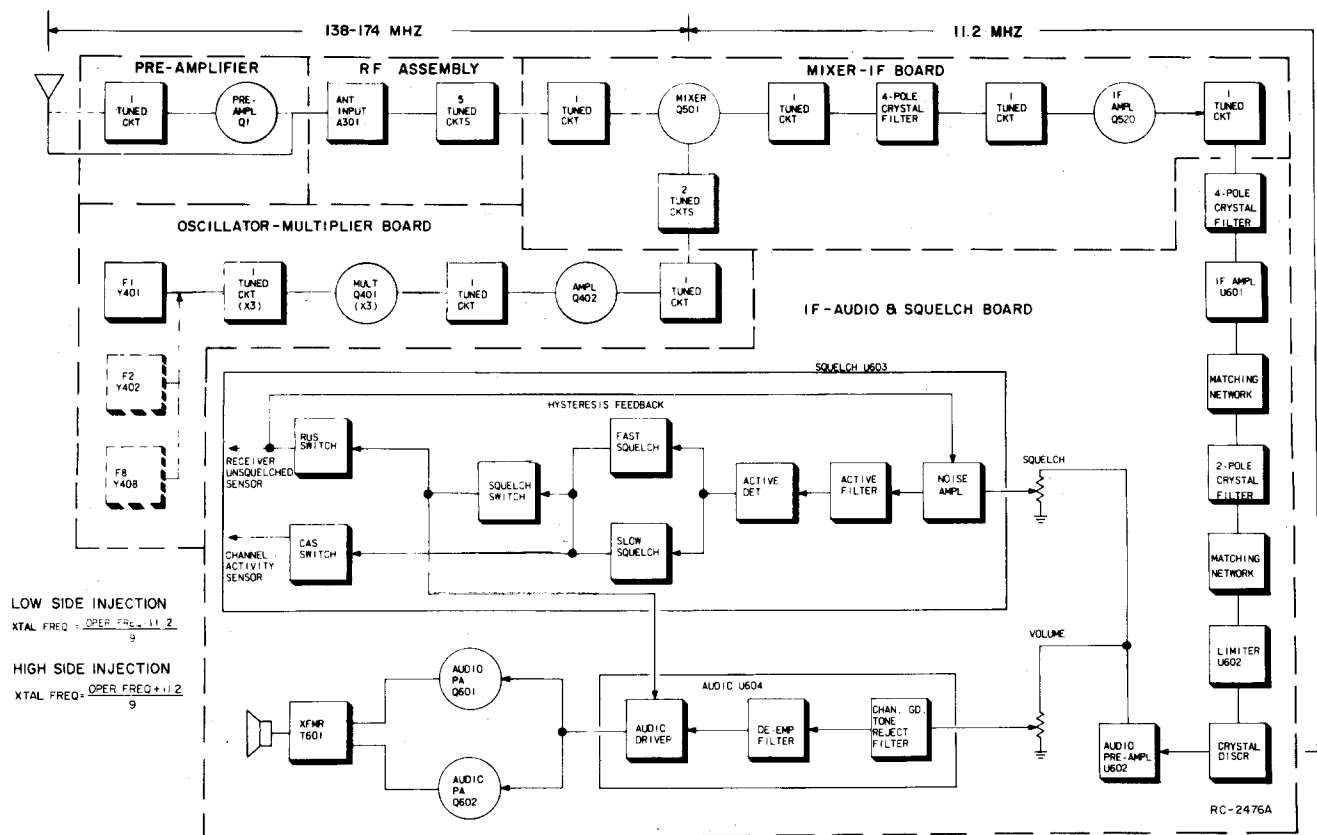

Figure 1 - Receiver Block Diagram

T2302 and connected to J1 on Antenna Input board A301 through cable W2302. T2302 is tapped to provide a 50-ohm output impedance. P2301 connects to J501 on the MIF board for the regulated +10-Volt supply voltage.

ANTENNA INPUT A301

An RF signal from the antenna or UHS pre-amplifier is applied to A301 which provides an AC ground between vehicle ground and receiver A-. Resistor R1 prevents a static charge from building up on the vehicle antenna. The output of A301 is coupled through five high Q helical resonators that provide the front end RF selectivity. The helicals are tuned to the incoming frequency by C301 through C305.

OSCILLATOR - MULTIPLIER

The oscillator-multiplier can be equipped with up to eight Integrated Circuit Oscillator Modules (ICOMs). The ICOM crystal frequencies range from approximately 14 to 18 megahertz, and the crystal frequency is multiplied nine times and then amplified to provide a low side injection frequency to the mixer. An optional modification kit is available for high side injection.

ICOMS

Three different types of ICOMs are available for use in the Osc/Mult module. Each of the ICOMs contains a crystal-controlled Colpitts oscillator, and two of the ICOMs contain compensator ICs. The different ICOMs are:

- 5C-ICOM - contains an oscillator and a 5 part-per-million ($\pm 0.0005\%$) compensator IC. Provides compensation for EC-ICOMs.
- EC-ICOM - contains an oscillator only. Requires external compensation from a 5C-ICOM.
- 2C-ICOM - contains an oscillator and a 2 PPM ($\pm 0.0002\%$) compensator IC. Will not provide compensation for an EC-ICOM.

The ICOMs are enclosed in an RF shielded can with the type ICOM (5C-ICOM, EC-ICOM or 2C-ICOM) printed on the top of the can. Access to the oscillator trimmer is obtained by prying up the plastic tab on the top of the can. The tabs can also be used to pull the ICOMs out of the radio.

Frequency selection is accomplished by switching the ICOM keying lead (terminal 6) to A- by means of the frequency selector switch on the control unit. In single-frequency radios, a jumper from H9 to H10 in the control unit connects terminal 6 of the ICOM to A-. In the receive mode, +10 Volts is applied to the external

ICOM load resistor (R401) by the RX Osc control line, keeping the selected ICOM turned on. Keying the transmitter removes the 10 Volts at R401, turning the ICOM off.

CAUTION

All ICOMs are individually compensated at the factory and cannot be repaired in the field. Any attempt to repair or change an ICOM frequency will void the warranty.

In standard 5 PPM radios using EC-ICOMs, at least one 5C-ICOM must be used. The 5C-ICOM is normally used in the receiver F1 position, but can be used in any transmitter or receive position. One 5C-ICOM can provide compensation for up to 15 EC-ICOMs in the transmitter and receiver. Should the 5C-ICOM compensator fail in the open mode, the EC-ICOMs will still maintain 2 PPM frequency stability from 0°C to 55°C (+32°F to 131°F) due to the regulated compensation voltage (+5 Volts) from the 10-Volt regulator IC. If desired, up to 16 5C-ICOMs may be used in the radio.

The 2C-ICOMs are self-compensated to 2 PPM and can not provide compensation for EC-ICOMs.

Oscillator Circuit

The quartz crystals used in ICOMs exhibit the traditional "S" curve characteristics of output frequency versus operating temperature.

At both the coldest and the hottest temperatures, the frequency increases with increasing temperature. In the middle temperature range (approximately 0°C to +55°C), frequency decreases with increasing temperature.

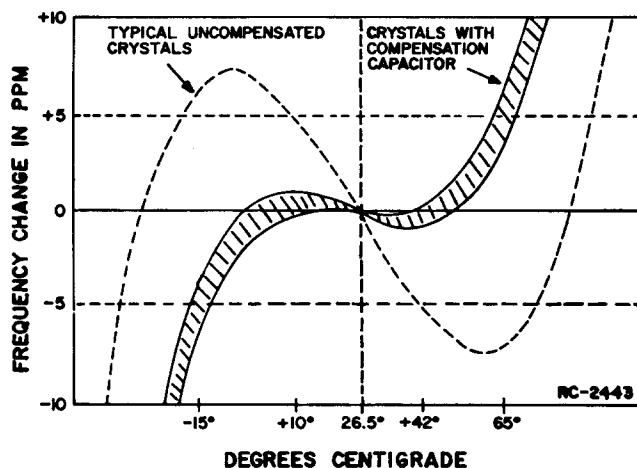

Figure 2 - Typical Crystal Characteristics

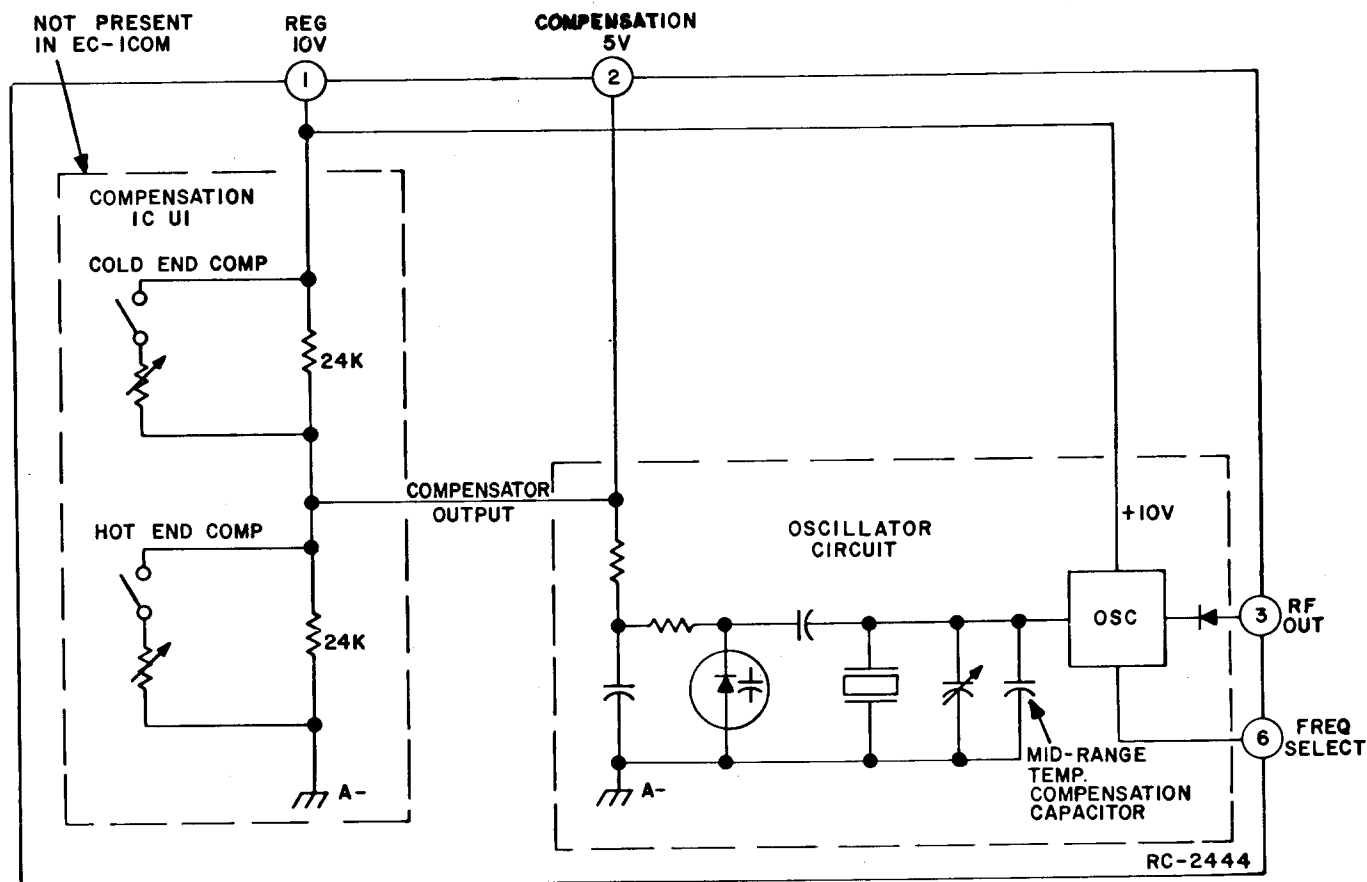

Figure 3 - Equivalent ICOM Circuit

Since the rate of change is nearly linear over the mid-temperature range the output frequency change can be compensated by choosing a parallel compensation capacitor with a temperature coefficient approximately equal and opposite that of the crystal.

Figure 2 shows the typical performance of an uncompensated crystal as well as the typical performance of a crystal which has been matched with a properly chosen compensation capacitor.

At temperatures above and below the mid-range, additional compensation must be introduced. An externally generated compensation voltage is applied to a varactor (voltage-variable capacitor) which is in parallel with the crystal.

A constant bias of 5 Volts (provided from Regulator IC U901 in parallel with the compensator) establishes the varactor capacity at a constant value over the entire mid-temperature range. With no additional compensation, all of the oscillators will provide 2 PPM frequency stability from 0°C to 55°C (+32°F to 131°F).

Compensator Circuits

Both the 5C-ICOMs and 2C-ICOMs are temperature compensated at both ends of the temperature range to provide instant frequency compensation. An equivalent ICOM circuit is shown in Figure 3.

The cold end compensation circuit does not operate at temperatures above 0°C. When the temperature drops below 0°C, the circuit is activated. As the temperature decreases, the equivalent resistance decreases and the compensation voltage increases.

The increase in compensation voltage decreases the capacity of the varactor in the oscillator, increasing the output frequency of the ICOM.

The hot end compensation circuit does not operate at temperatures below +55°C. When the temperature rises above +55°C, the circuit is activated. As the temperature increases, the equivalent resistance decreases and the compensation voltage decreases. The decrease in compensation voltage increases the capacity of the varactor, decreasing the output frequency of the ICOM.

Service Note: Proper ICOM operation is dependant on the closely-controlled input voltages from the 10-Volt regulator. Should all of the ICOMs shift off frequency, check the 10-Volt regulator module.

MULTIPLIER & AMPLIFIER

The output of the Selected ICOM is coupled through a tuned circuit (L401 and C405) that is tuned to three times the crystal frequency. The output of the tuned circuit is applied to the base of a Class C multiplier, Q401. The collector tank circuit of the multiplier (L402 and C409) is tuned to nine times the crystal frequency. The multiplier stage is metered at metering jack J601-3 on the IFAS board.

Following the multiplier is a Class A Amplifier stage, Q402. Q402 is metered at J601-4 on the IFAS board through a metering network consisting of C415, C416, CR401 and R408. The amplified output of Q402 is applied to a tuned circuit (L403 and C413) that is tuned to nine times the crystal frequency. The tuned circuit provides some selectivity in the oscillator-multiplier chain.

MIXER-IF

MIXER & CRYSTAL FILTER

The mixer uses a FET (Q501) as the active device. The FET mixer provides a high input impedance, high power gain, and an output relatively free of harmonics (low in intermodulation products).

In the mixer stage, RF from the helical resonators is coupled through L502 and C502 which matches the RF output to the gate of mixer Q501. Injection voltage from the multiplier-selectivity stages is applied to the source of the mixer. The 11.2 MHz mixer IF output signal is coupled from the drain of Q501 through a tuned circuit (L505 and C505) which matches the mixer output to the input of the four-pole monolithic crystal filter. The highly-selective crystal filter (FL501 and FL502) provides the first portion of the receiver IF selectivity. The output of the filter is coupled through impedance-matching network L520 and C523 to the IF amplifier.

Service Note: Variable capacitor C521 does not require adjustment when performing normal alignment. If the four-pole monolithic crystal filter is replaced, then adjustment of C521 is necessary for optimum IF response.

IF AMPLIFIER

IF amplifier Q520 is a dual-gate FET. The filter output is applied to Gate 1 of the amplifier, and the output is taken from the drain. The biasing on Gate 2 and the drain load determines the gain of the stage. The amplifier provides approximate-

ly 20 dB of IF gain. The output of Q520 is coupled through a network (L521 and C528) that matches the amplifier output to the crystal filter on the IFAS board. The output of the MIF board is applied to the IFAS board through feed-through capacitor C325.

Supply voltage for the RF amplifier and MIF board is supplied from the IFAS board through feed-through capacitor C326.

IF-AUDIO & SQUELCH

CRYSTAL FILTERS, IF AMP & LIMITER

IF from the MIF board is applied to a second four-pole monolithic crystal filter (FL601 and FL602) for additional selectivity. Following the filter circuits (FL601 and FL602) are impedance matching networks C601, L609, and R621, and C603 and L601 respectively. The output of the filter is applied to IF amplifier IC (U601). The amplifier IC provides approximately 60 dB of IF gain.

Following U601 is matching network L602 and C607, and two-pole crystal filter FL603 which provides the final receiver IF selectivity. The filter output is applied to impedance matching circuit C612 and L603. The IF signal is coupled through C611 to the limiter IC (U602). The limiter IC provides approximately 60 dB of IF gain. The IF amplifier output is metered at J601 through metering network C613, C614, L604 and CR601.

Service Note: Variable capacitors C601, C603, C607 and C612 do not require adjustment when performing normal alignment. If the 4-pole crystal filter or the 2-pole crystal filter is replaced, then adjustment of the associated capacitors will be necessary to achieve optimum IF response.

DISCRIMINATOR & AUDIO PRE-AMP

The limiter output is applied to a Foster-Seely crystal discriminator where diodes CR602 and CR603 recover the audio. L605 is adjusted for zero discriminator reading. The discriminator is metered at J601-2 through R616.

The discriminator output is coupled through potentiometer R614 which is adjusted to set the audio level to the audio pre-amp IC (U602). The pre-amp provides approximately 26 dB of audio gain.

Service Note: R614 does not normally require adjustment unless U602 or parts of the discriminator are replaced. If adjustment should be required, set R614 for one Volt RMS measured at P904-11 with a 1000 microvolt signal with 1 kHz modulation and 3 kHz deviation applied to the antenna jack.

The output of the audio pre-amp is coupled through a low-pass filter (L607 and C636) to VOLUME and SQUELCH control high. The filter removes any IF signal remaining in the audio output of the pre-amp.

AUDIO IC

The hybrid audio IC (U604) uses a custom flip-chip monolithic integrated circuit. The audio IC contains a standard EIA Channel Guard tone reject filter, a receiver de-emphasis circuit, and the low level audio PA drive circuitry.

Audio from the pre-amp is coupled through the VOLUME control to pin 4 of the audio IC from P904-13 (VOL ARM). Audio at pin 4 is applied to the Channel Guard tone reject circuit, and then to the 6 dB/octave de-emphasis circuit. The filter output through C635 to the differential audio driver circuit. The output of the audio driver circuit is DC-coupled to the push-pull, Class AB audio PA transistors, Q601 and Q602. The PA output is coupled through audio transformer T601 to provide a low distortion, 12-Watt output to the 8-ohm loudspeaker. R619 and C637 in the transformer secondary protects the PA transistors against a "no-load" or open circuit. Feedback from windings T601-3 and -4 determines the gain of the audio driver amplifier.

When the receiver is squelched, pin 1 of audio IC U604 is near A-, and the entire audio circuit is turned OFF to eliminate current drain. Pin 1 is also connected to the system board through P904-7 (RX MUTE) so that the receiver audio can be disabled by the time delay circuit in the 10-Volt regulator, and by the Channel Guard option when used.

Pins 6 and 7 are connected to the system board through P904-16 (RX PA) and P904-21 (INTCM INPUT) so that the receiver audio stages can be used to provide an audio output when the radio is equipped with the Intercom option.

Pin 2 is connected to the system board through P904-6 (SQ DISABLE) so that the receiver audio stages can be independently activated and used to provide an alert tone output when the radio is equipped with the Carrier Controlled Timer option.

SQUELCH IC

The hybrid squelch IC (U603) also uses a custom flip-chip monolithic integrated circuit. The squelch IC contains the noise amplifier, active noise filter, detector, slow and fast squelch circuits as well as the receiver unsquelched sensor (RUS) switch, and carrier activity sensor (CAS) switch.

Noise Amp, Filter & Active Detector

Noise from the discriminator is coupled through the SQUELCH control to pins 1 and 2 on the squelch IC. This signal is applied to the noise amplifier and then to the active filter circuit.

The noise amp and active filter provide the gain and selectivity to distinguish between noise and audio. The filter output drives the active detector circuit to provide the squelch switching functions. Thermistor RT601 keeps the input to the active detector constant over wide variations in temperature.

Slow & Fast Squelch

With a signal below the 20 dB quieting level, the slow squelch circuit provides a conventional slow (200 millisecond) squelch operation to prevent rapid squelch opening and closing in weak signal areas.

A signal at or above the 20 dB quieting level is sensed by the signal level detector and activates the fast squelch circuit, providing a fast (10 millisecond) squelch operation.

The squelch circuits have two outputs. One output controls the squelch switch and the other output controls the CAS switch.

Squelch Switch

The squelch switch output at pin 7 is connected to pin 1 of the audio IC. When the receiver is squelched, the output pin at 7 is near A-. This keeps the receiver audio stages turned off, muting the receiver. When the receiver is quieted by an on-frequency signal (unsquelches), the voltage at pin 7 rises to approximately +10 Volts. This turns on the audio stages and sound is heard at the speaker.

With the receiver unsquelched, the output of the squelch switch turns on the RUS switch. The output of the RUS switch is connected to the noise amplifier, providing a hysteresis loop in the squelch circuit. The RUS output increases the gain of the noise amplifier, preventing squelch closing on weak signals. The RUS output at pin 8 is also connected to the system board through P904-8 for special applications.

NOTE

In Channel Guard radios, the RUS switch will operate only when an on-frequency signal with the correct Channel Guard tone is applied to the receiver.

CAS Switch

The squelch circuits also drive the CAS switch. When the receiver unsquelches,

the voltage at pin 6 rises to approximately 10 Volts. This voltage is connected to the system board through P904-9, and is used to turn on an optional Channel busy light on the Control Unit.

NOTE

The CAS switch will operate whenever an on-frequency signal is received, with or without a correct Channel Guard tone.

MAINTENANCE

DISASSEMBLY

To service the Receiver from the top (see Mechanical Parts Breakdown):

1. Pull the locking handle down, then pry up the top cover at the front notch and lift off the cover.

To service the Receiver from the bottom:

1. Pull the locking handle down and pull the radio out of the mounting frame.
2. Remove the top cover, then loosen the two bottom cover retaining screws and remove the bottom cover (see Figure 4).

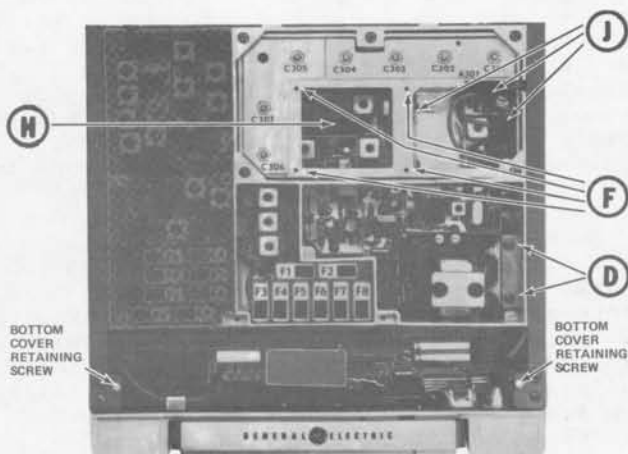

Figure 4 Disassembly Procedure (Top View)

To remove the MIF board from the radio:

1. Remove the seven screws (E) holding the MIF bottom cover.
2. Remove the four screws (F) holding the MIF top cover.
3. Remove the two screws (G) and the Connector (H), and carefully push down on the top of the board to avoid damaging the feedthrough capacitors.

3. To gain access to the bottom of the Osc/Mult and IFAS board, remove the six screws (A) holding the receiver bottom cover (see Figure 5).

To remove the OSC/Mult board from the radio:

1. Remove the six screws (A) holding the receiver bottom cover.
2. Remove the seven screws (E) holding the MIF bottom cover.
3. Remove the four screws (B) holding the board.
4. Press straight down on the plug-in Osc/Mult board from the top to avoid bending the pins when unplugging the board from the system board jack.

To remove the IFAS board from the radio:

1. Remove the six screws (A) holding the bottom cover, and the one screw (C) holding the board.
2. Remove the two screws (D) holding the audio PA heatsink to the right side rail.
3. Press straight down on the plug-in IFAS board from the top to avoid bending the pins when unplugging the board from the system board jack.

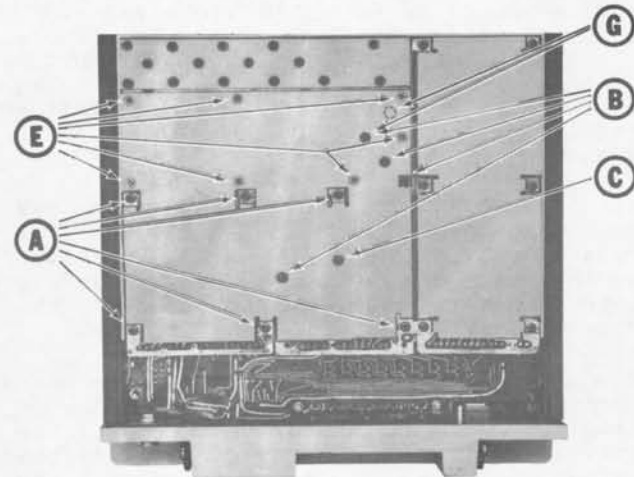

Figure 5 Disassembly Procedure (Bottom View)

To remove the optional UHS pre-amplifier board:

1. Remove the seven screws (E) holding the MIF bottom cover, and the four screws (F) holding the MIF top cover.
2. Disconnect the two connectors and 10-Volt lead (J).
3. Remove the two screws on the bottom side of the board, and lift out the board.



ADDENDUM TO LBI-4561

138-174 MHz MASTR II RECEIVERS

USING

OSCILLATOR/MULTIPLIER BOARD 19D423241G1-4 AND IF/AUDIO

SQUELCH BOARD 19D417707G1,2

TABLE OF CONTENTS

DESCRIPTION	Page 1
RECEIVER ALIGNMENT INSTRUCTIONS	Page 3
TEST PROCEDURE	Page 4
TROUBLESHOOTING PROCEDURE	Page 5
MAINTENANCE MANUAL, OSCILLATOR/MULTIPLIER	LBI-4984
MAINTENANCE MANUAL, IF/AUDIO/SQUELCH	LBI-4986

DESCRIPTION

This addendum contains information for servicing MASTR II receivers using Oscillator/Multiplier Boards 19D423241G1-4 or 19D416610G1-4 and IF/AUDIO/Squelch Boards 19D417707G1,2 or 19D416606G1,2. Since MASTR II receivers may contain any combination of these boards, two complete sets of receiver alignment, test and troubleshooting procedures are provided.

or OSC/MULT board 19D423241G1-4 and IFAS board 19D416606G1,2, are used, the alignment instructions must be tailored to each individual receiver. The following paragraphs identify the procedures required to properly align these receivers.

NOTE

The part number identifying each board is marked on the component side of the board.

NOTE

The following procedures require the use of the Receiver Alignment Procedure contained in LBI-4561 and the Receiver Alignment Procedure contained in this addendum.

For receivers using OSC/MULT board 19D416610G1-4 and IFAS board 19D416606G1,2, refer to LBI-4561 for service information.

For receivers using OSC/MULT board 19D423241G1-4 and IFAS board 19D417707G1,2, service information is provided in this addendum.

FRONT END ALIGNMENT FOR

OSC/MULT BOARD 19D416610G1-4 AND IFAS BOARD 19D417707G1,2

PROCEDURE

- A. Steps 1 and 2 in LBI-4561.
- B. Steps 4 thru 6 in Addendum.

NOTE

Service information for OSC/MULT board 19D423241G1-4 contained in LBI-4984 is also provided in Datafile Folder 1106. Service information for IFAS board 19D417707G1,2 contained in LBI-4986 is also provided in Datafile Folder 1105.

FRONT END ALIGNMENT FOR

OSC/MULT BOARD 19D423241G1-4 AND IFAS BOARD 19D416606G1,2

PROCEDURE

- A. Steps 1 thru 3 in Addendum.
- B. Steps 3 thru 5 in LBI-4561.

When combinations of OSC/MULT board 19D416610G1-4 and IFAS board 19D417707G1,2,

Addendum to LBI-4561

COMPLETE RECEIVER ALIGNMENT
FOR
OSC/MULT BOARD 19D416610G1-4 AND
IFAS BOARD 19D417707G1,2

PROCEDURE

- A. Steps 1 and 2 in Addendum.
- B. Steps 3 and 4 in LBI-4561.
- C. Steps 6 thru 15 in Addendum.

COMPLETE RECEIVER ALIGNMENT
FOR
OSC/MULT BOARD 19D423241G1-4 AND
IFAS BOARD 19D416606G1,2

PROCEDURE

- A. Steps 1 and 2 in LBI-4561.
- B. Steps 3 thru 5 in Addendum.
- C. Steps 5 thru 14 in LBI-4561.

ICOM FREQUENCY ADJUSTMENT

First, check the frequency to determine if any adjustment is required. The frequency measurement requires equipment with an absolute accuracy which is 5 to 10 times better than the tolerance to be maintained. When performing frequency measurement, the entire radio should be as near as possible to an ambient temperature of 26.5°C (79.8°F).

MASTR II ICOMs should be reset only when the measured frequency error exceeds the following limits:

- ±0.5 PPM, when the radio is at 26.5°C (79.8°F).
- ±2 PPM at any other temperature within the range -5°C to +55°C (+23°F to +131°F).
- The specification limit (±2 PPM or ±5 PPM) at any temperature within the ranges -40°C to -5°C (-40°F to +23°F) or +55°C to +70°C (+131°F to 158°F).

If frequency adjustment is required, lift up the cover on the top of the ICOM to expose the adjustment trimmer. Depending upon the type of frequency measuring equipment that is available, any of the following procedures may be used:

A. DIRECT MEASUREMENT IN THE INJECTION CHAIN

- WITH A FREQUENCY COUNTER. "Count" the frequency at the junction of C418 and C419 on the Oscillator/Multiplier Board. The frequency measured at this point is 9 times the ICOM frequency. NOTE: The output from the ICOM itself is not sufficiently sinusoidal for reliable operation with most frequency counters.
- WITH A COMMUNICATION MONITOR (for example: Cushman Model CE-3). "Monitor" frequency at the junction of C418 and C419 on the Oscillator/Multiplier Board. The frequency monitored at this point is 9 times the ICOM frequency. NOTE: This frequency will not always fall within an available measuring range of all monitors at all receiver operating frequencies.

B. STANDARD "ON FREQUENCY" SIGNAL AT THE RECEIVER INPUT (Generated from a COMMUNICATION MONITOR, for example: Cushman Model CE-3).

- WITH A FREQUENCY COUNTER. "Count" the developed IF frequency at the tap of Z602-R2 on the IFAS board. The deviation from the nominal IF frequency (11.2 MHz) in Hz is compared to the receiver operating frequency (also in Hz) to calculate error in PPM.
- WITH AN 11.2 MHZ IF FREQUENCY STANDARD (for example: General Electric Model 4EX9A10). Loosely couple the IF frequency standard to the IF signal path to create a heterodyne with the developed IF frequency. The resultant "beat frequency" can be monitored by either of the following methods:

NOTE

To Set ICOM frequency using "beat frequency" method, the temperature should be at 26.5°C (79.8°F). If the temperature is not 26.5°C, then offset the "ON FREQUENCY" signal (at the receiver's input), as a function of actual temperature, by the frequency ERROR FACTOR (in PPM) shown in Figure 2.

- Audible "beat frequency" from the receiver speaker (this requires careful frequency adjustment of the frequency standard).
- Observe "beat frequency" at P904-4 with an Oscilloscope.
- With GE TEST SET (Meter Position B) connected to J601 on the IFAS Board, visually observe the "beat frequency" indicated by meter movement.

The frequency of the "beat" is the frequency error, related to the IF frequency. This deviation, in Hz, is compared to the receiver operating frequency, also in Hz, to calculate the error in PPM.

NOTE

The FM DETECTOR output (Meter Position A of the Test Set) is provided for routine test and measurement only. The limited resolution available (0.025 V per kHz as measured with GE Test Set in Meter Position A, or 0.1 V per kHz as measured with a VTVM at P904-3 or J601-2 on the IFAS board) is inadequate for oscillator frequency setting.

If the radio is at an ambient temperature of 26.5°C (79.8°F) set the oscillator for the correct mixer frequency (ICOM FREQ. X 9).

If the radio is not at an ambient temperature of 26.5°C, setting errors can be minimized as follows:

A. To hold setting error to ±0.6 PPM (which is considered reasonable for 5 PPM ICOMs):

- Maintain the radio at 26.5°C (±5°C) and set the oscillator to required mixer injection frequency, or
- Maintain the radio at 26.5°C (±10°C) and offset the oscillator, as a function of actual temperature, by the frequency error factor shown in Figure 2.

B. To hold setting error to ±0.35 PPM (which is considered reasonable for 2 PPM ICOMs): Maintain the unit at 26.5°C (±5°C) and offset the oscillator, as a function of actual temperature, by the frequency error factor shown in Figure 2.

For example: Assume the ambient temperature of the radio is 18.5°C (65.4°F). At that temperature, the curve shows a correction factor of 0.3 PPM. (At 138 MHz, 1 PPM is 138 Hz. At 174 MHz, 1 PPM is 174 Hz).

With a mixer injection frequency of 150 MHz, adjust the oscillator for a corrected mixer injection frequency 45 Hz (0.3 X 150 Hz) higher. If a negative correction factor is obtained (at temperatures above 26.5°C), set the oscillator for the indicated PPM lower than the calculated mixer injection frequency.

DEGREES FAHRENHEIT

61.8 65.4 69.0 72.6 76.6 79.8 83.4 87.0 90.6 94.2 97.8

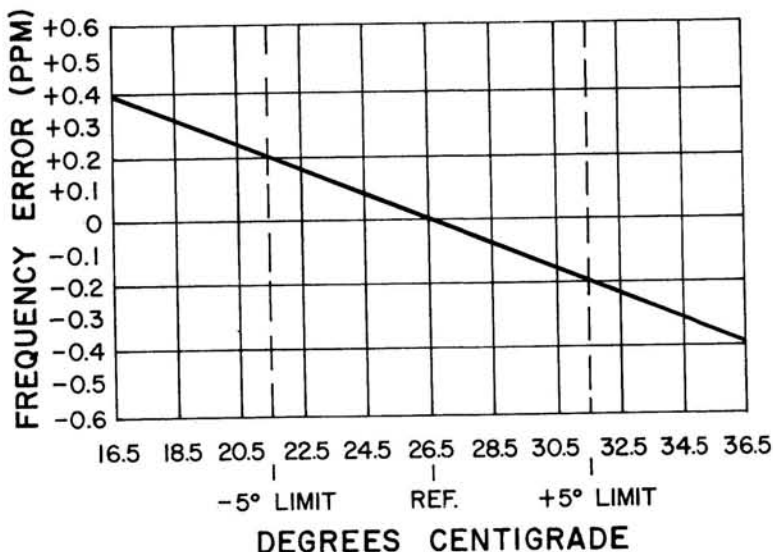

RC-2453

Figure 2 - Frequency Characteristics Vs. Temperature

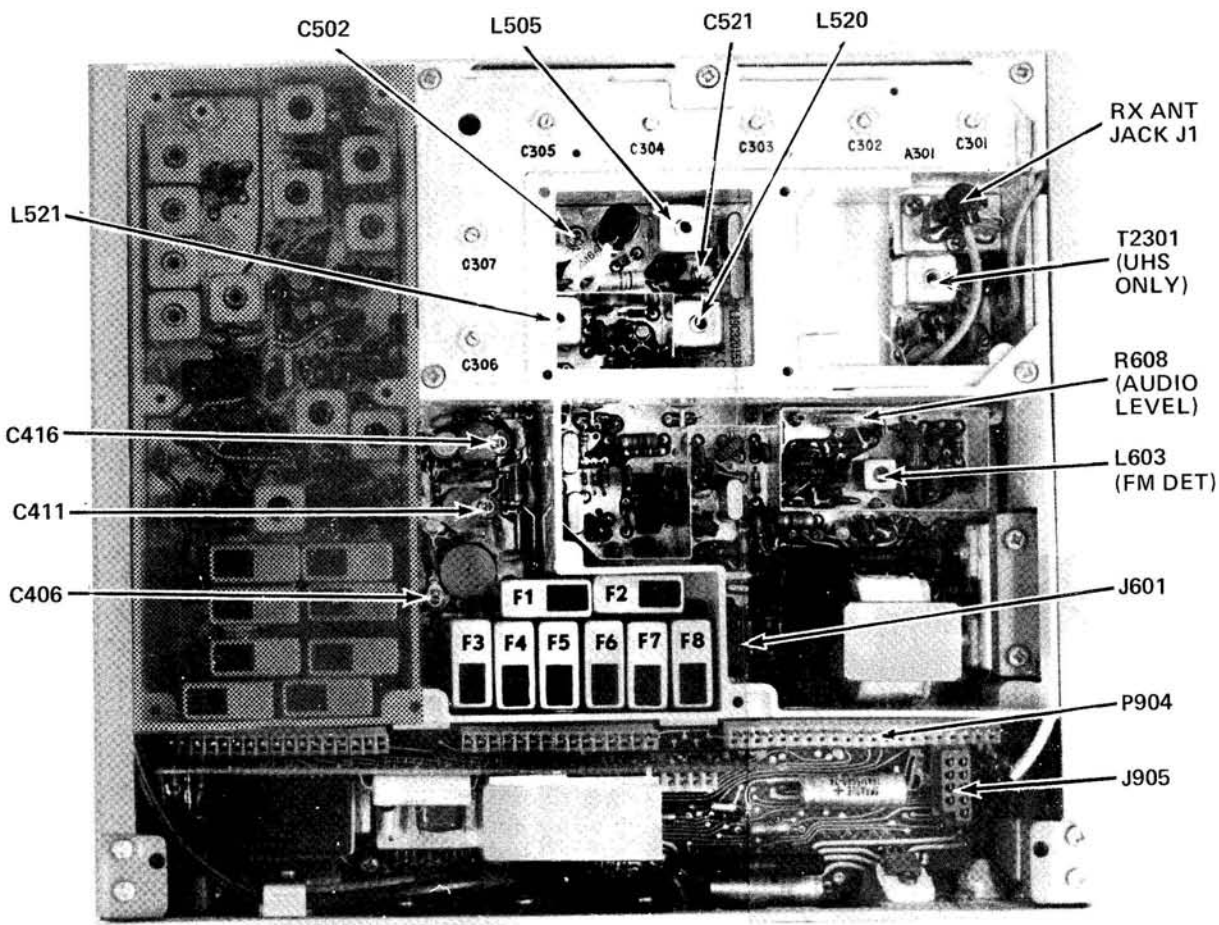

NOTE 1: Appendix A of DATAFILE Bulletin 1000-6 contains instructions for building a sweep modulator.

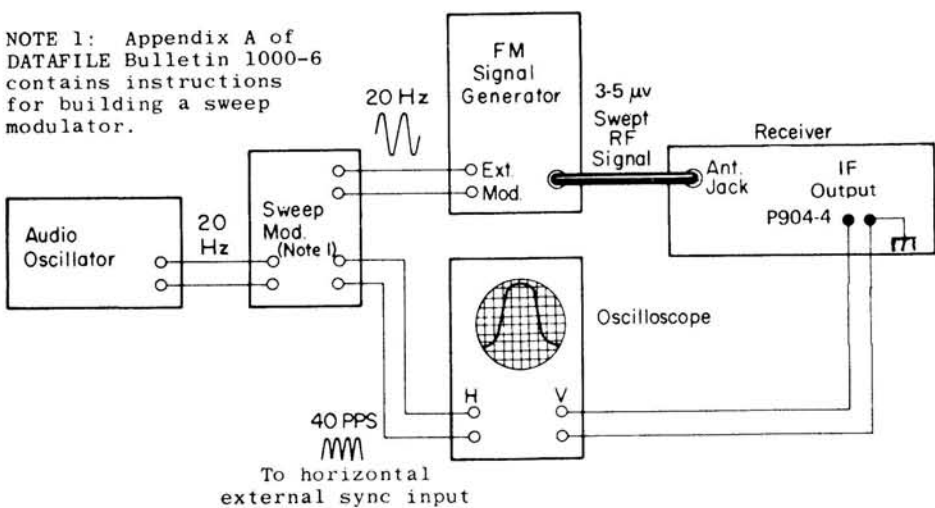

Figure 1 - Test Setup for 20-Hz Double-Trace Sweep Alignment

FRONT END ALIGNMENT

EQUIPMENT

1. GE Test Set Models 4EX3A11, 4EX8K12, or 20,000 ohms-per-Volt multimeter with a 1-Volt scale.
2. A 138-174 MHz signal source.

PRELIMINARY CHECKS AND ADJUSTMENTS

1. Connect black plug from Test Set to Receiver Centralized Metering Jack J601, and red plug to system board metering jack J905. Set range selector switch to the TEST 1 position (or 1-Volt position on 4EX8K12).
2. For multi-frequency receivers with a frequency spacing up to 0.450 MHz for frequency range of 138-155 MHz, or 0.500 MHz for frequency range of 150.8-174 MHz, align the receiver on the channel nearest center frequency.

For multi-frequency receivers with a frequency spacing exceeding the above but no greater than .900 MHz for frequency range of 138-155 MHz, or 1.00 MHz for frequency range of 150.8-174 MHz, align the receiver using a center frequency tune-up ICOM. These limits can be extended to 1.60 MHz, and 1.80 MHz respectively, with 3 dB degradation in standard receiver specifications.

3. With Test Set in Position J, check for regulated +10 Volts. If using multimeter, measure between J905-3 (+) and J905-9 (-).
4. If using multimeter, connect the negative lead to J601-9 (A-).
5. Disable Channel Guard.

ALIGNMENT PROCEDURE

STEP	METERING POSITION		TUNING CONTROL	METER READING	PROCEDURE
	GE Test Set	Multimeter - at J601-9			
OSCILLATOR/MULTIPLIER					
1.	C (MULT-1)	Pin 3	C406	Maximum	Tune C406 for maximum meter reading.
2.			C411, C416, C306, C307	See Procedure	Preset C411 and C416 to a position similar to C406. Next, preset C306 and C307 fully counterclockwise (minimum capacity).
3.	D (MULT-2)	Pin 4	C411, C416, C406	See Procedure	Tune C411 and C416 for maximum meter reading. Next, retune C406, C411 and C416 for maximum meter reading, then, carefully dip C306 and Tune C307 for maximum meter reading. Do <u>NOT</u> readjust C306 and C307.
RF SELECTIVITY					
4.	A (FM DET)	Pin 2		0.38 Volt	Apply an on-frequency signal to the antenna jack. Adjust the signal generator for a meter reading of 0.38 Volt.
5.	B (IF AMP)	Pin 1	C502, C301 thru C305 (and T2301 if present)	Maximum	Apply an on-frequency signal to the antenna jack, keeping the signal below saturation. Then tune C502 and C301 through C305 for maximum meter reading. In receivers with the UHS preamplifier, also tune T2301 for maximum meter reading.
6.	B (IF AMP)	Pin 1	C502, C301 thru C305 (and T2301 if present)	Maximum	Apply an on-frequency signal to the antenna jack and slightly tune C502, C301 through C305 (and T2301 if present) for best quieting sensitivity.

COMPLETE RECEIVER ALIGNMENT

EQUIPMENT REQUIRED

- GE Test Set Models 4EX3A11, 4EX8K12 (or 20,000 ohms-per-Volt multimeter with a 1-Volt scale).
- An 11.2 MHz signal source (GE Test Set Model 4EX9A10). Also a 138-174 MHz signal source (Measurements 803) with a one-inch piece of insulated wire no larger than .065 inch diameter connected to generator probe.
- A VTVM.

PRELIMINARY CHECKS AND ADJUSTMENTS

- Connect the black plug from the Test Set to receiver metering jack J601, and the red plug to system board metering jack J905. Set the range selector switch to the Test 1 (or 1-Volt position on the 4EX8K12).
- For multi-frequency receivers with a frequency spacing up to 0.450 MHz for frequency range of 138-155 MHz, or 0.500 MHz for frequency range of 150.8-174 MHz, align the receiver on the channel nearest center frequency.

For multi-frequency receivers with a frequency spacing exceeding the above but no greater than .900 MHz for frequency range of 138-155 MHz, or 1.00 MHz for frequency range of 150.8-174 MHz, align the receiver using a center frequency tune-up ICON. These limits can be extended to 1.60 MHz, and 1.80 MHz respectively, with 3 dB degradation in standard receiver specifications.
- With the Test Set in Position J, check for regulated +10 Volts. With multimeter, measure from J905-3 to J905-9.
- If using multimeter, connect the negative lead to J601-9 (A-).
- Disable the Channel Guard.

ALIGNMENT PROCEDURE

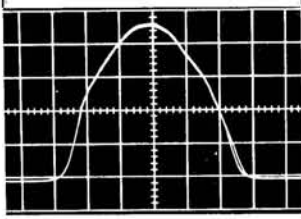
STEP	METERING POSITION		TUNING CONTROL	METER READING	
	GE Test Set	Multimeter - at J601-9			
FM DETECTOR					
1.	A (FM DET)	Pin 2	L603	0.38 Volt	Apply the correct IF signal between J624 and A-. Tune L603 for a meter reading of 0.38 Volts.
2.	A (FM DET)	Pin 2	R608	1 Volt RMS	Remove the Test Set metering plug from J601. Apply a 1000 microvolt signal with 1 kHz modulation and 3.0 kHz deviation to the antenna jack. Set R608 for 1 Volt RMS measured with a VTVM at P904-11 (VOL/SQ HI) and P904-17 (A-).
3.	C (MULT-1)	Pin 3	C406	Maximum	Re-connect the Test Set metering plug to J601. Tune C406 for maximum meter reading.
4.			C411, C416, C306, C307	See Procedure	Preset C411 and C416 to a position similar to C406. Next, preset C306 and C307 fully counterclockwise (minimum capacity).
5.	D (MULT-2)	Pin 4	C411, C416, C406	See Procedure	Tune C411 and C416 for maximum meter reading. Next, retune C406, C411 and C416 for maximum meter reading, then, carefully dip C306 and tune C307 for maximum meter reading. Do NOT readjust C306 and C307.
RF SELECTIVITY					
6.	A (FM DET)	Pin 2		0.38 Volts	Apply an on-frequency signal in the hole adjacent to C305. Adjust the signal generator for a meter reading of 0.38 Volts.
7.	B (IF AMP)	Pin 1	C502	Maximum	Apply the signal as in Step 6 and tune C502 for maximum meter reading.
8.	B (IF AMP)	Pin 1	C305	Maximum	Apply an on-frequency signal in the hole adjacent to C304, keeping the signal below saturation. Then tune C305 for maximum meter reading.
9.	B (IF AMP)	Pin 1	C304	Maximum	Apply an on-frequency signal in the hole adjacent to C303, keeping the signal below saturation. Then tune C304 for maximum meter reading.
10.	B (IF AMP)	Pin 1	C303	Maximum	Apply an on-frequency signal in the hole adjacent to C302, keeping the signal below saturation. Then tune C303 for maximum meter reading.
11.	B (IF AMP)	Pin 1	C302 and C301	Maximum	Apply an on-frequency signal to the antenna jack, keeping the signal below saturation. Then tune C302 and C301 for maximum meter reading.
12.	B (IF AMP)	Pin 1	C502, C301 thru C305 (and T2301 if present)	Maximum	Apply an on-frequency signal to the antenna jack, keeping the signal below saturation. Then tune C502 and C301 through C305 for maximum meter reading. In receivers with the URS preamplifier, also tune T2301 for maximum meter reading.
13.	B (IF AMP)	Pin 1	C502, C301 thru C305 (and T2301 if present)	Maximum	Apply an on-frequency signal to the antenna jack and slightly tune C502 and C301 through C305 (and T2301 if present) for best quieting sensitivity.
MIXER & IF					
The mixer and IF circuits have been aligned at the factory and will normally require no further adjustment. If adjustment is necessary, use the procedure outlined in Step 14.					
NOTE					
Refer to DATAFILE BULLETIN 1000-6 (IF Alignment of Two-Way Radio FM Receivers) for helpful suggestions on how to determine when IF Alignment is required.					
14.			L505, L520, L521 and C521		Connect scope, signal generator, and probe as shown in Figure 1. Set signal generator level for 3 to 5 μ V and modulate with 10 kHz at 20 Hz. With probe between P904-4 (or J601-1) and A-, tune L505, L520, L521 and C521, for double trace as shown on scope pattern.
					
15.				See Procedure	Check to see that modulation acceptance bandwidth is greater than ± 6.5 kHz.

TEST PROCEDURES

These Test Procedures are designed to help you to service a receiver that is operating---but not properly. The problems encountered could be low power, poor sensitivity, distortion, limiter not operating properly, and low gain. By following the sequence of test steps starting with Step 1, the defect can be quickly localized. Once

TEST EQUIPMENT REQUIRED

- Distortion Analyzer similar to: Heath IM-12
- Signal Generator similar to: Measurements 803
- 6-dB attenuation pad, and 8.0-ohm, 15-Watt resistor

the defective stage is pin-pointed, refer to the "Service Check" listed to correct the problem. Additional corrective measures are included in the Troubleshooting Procedure. Before starting with the Receiver Test Procedures, be sure the receiver is tuned and aligned to the proper operating frequency.

PRELIMINARY ADJUSTMENTS

1. Connect the test equipment to the receiver as shown for all steps of the receiver Test Procedure.
2. Turn the SQUELCH control fully clockwise for all steps of the Test Procedure.
3. Turn on all of the equipment and let it warm up for 20 minutes.

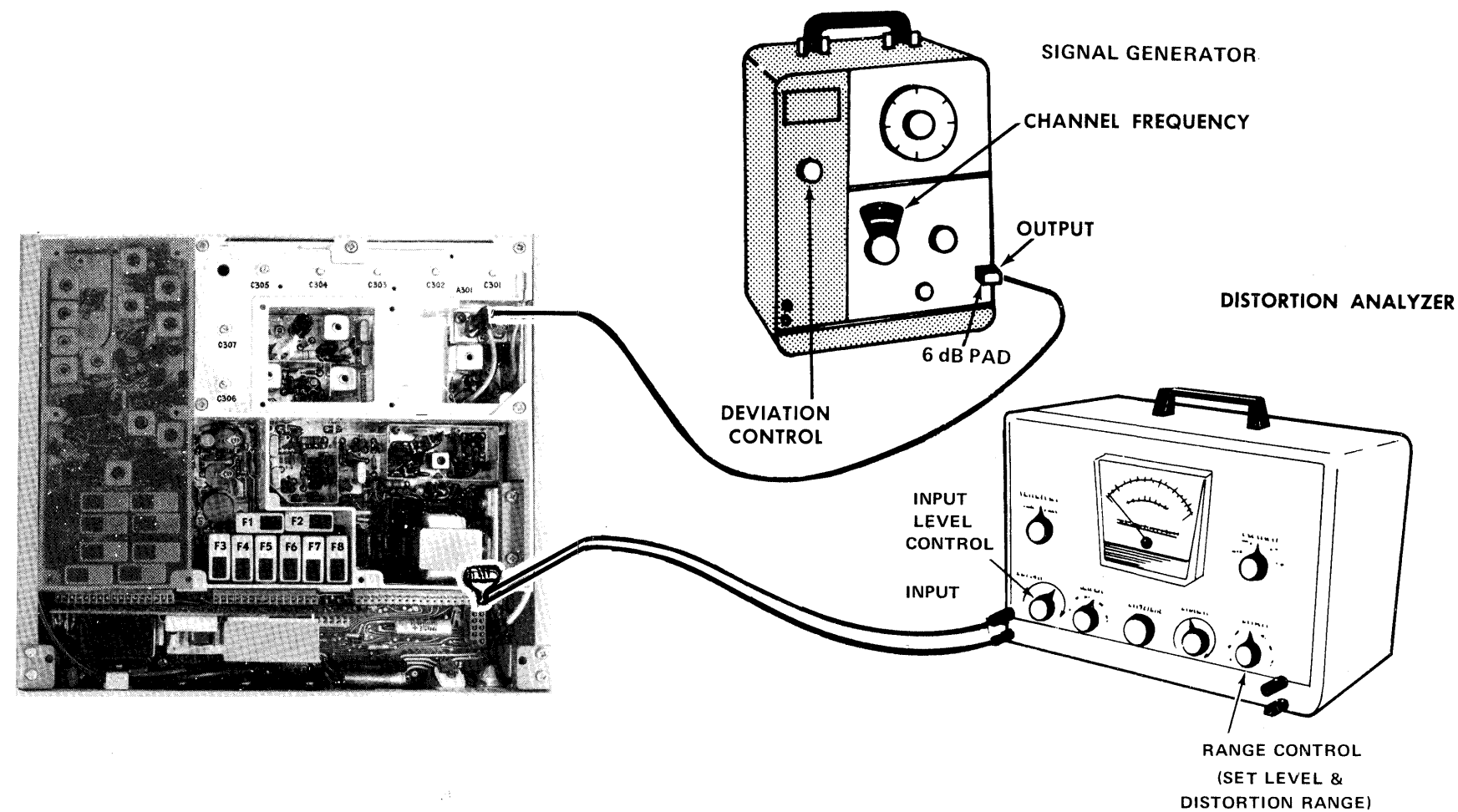

STEP 1 AUDIO POWER OUTPUT AND DISTORTION

TEST PROCEDURE

Measure Audio Power Output as follows:

- A. Apply a 1,000-microvolt, on-frequency test signal modulated by 1,000 hertz with ± 3.0 kHz deviation to antenna jack A301-J1.
- B. With 15-Watt Speaker:

Disconnect speaker lead pin from Systems Plug P701-11 (on rear of Control Unit).

Connect an 8.0-ohm, 15-Watt load resistor from P904-19 to P904-18 or from P701-4 to P701-17 (SPEAKER Hi) on the System Plug. Connect the Distortion Analyzer input across the resistor as shown.

OR

With Handset:

Lift the handset off of the hookswitch. Connect the Distortion Analyzer input from P904-19 to P904-18.

- C. Adjust the VOLUME control for 12-Watt output 9.8 VRMS using the Distortion Analyzer as a VTVM.
- D. Make distortion measurements according to manufacturer's instructions. Reading should be less than 3%. If the receiver sensitivity is to be measured, leave all controls and equipment as they are.

SERVICE CHECK

If the distortion is more than 3%, or maximum audio output is less than 12.0 Watts, make the following checks:

- E. Battery and regulator voltage---low voltage will cause distortion. (Refer to Receiver Schematic Diagram for voltages.)
- F. Audio Gain (Refer to Receiver Troubleshooting Procedure.)
- G. Discriminator Alignment (Refer to Receiver Alignment on reverse side of page).

STEP 2 USABLE SENSITIVITY (12-dB SINAD)

If STEP 1 checks out properly, measure the receiver sensitivity as follows:

- A. Apply a 1000-microvolt, on-frequency signal modulated by 1000 Hz with 3.0-kHz deviation to A301-J1.
- B. Place the RANGE switch on the Distortion Analyzer in the 200 to 2000-Hz distortion range position (1000-Hz filter in the circuit). Tune the filter for minimum reading or null on the lowest possible scale (100%, 30%, etc.)
- C. Place the RANGE switch to the SET LEVEL position (filter out of the circuit) and adjust the input LEVEL control for a +2 dB reading on a mid range (30%).
- D. While reducing the signal generator output, switch the RANGE control from SET LEVEL to the distortion range until a 12-dB difference (+2 dB to -10 dB) is obtained between the SET LEVEL and distortion range positions (filter out and filter in).
- E. The 12-dB difference (Signal plus Noise and Distortion to noise plus distortion ratio) is the "usable" sensitivity level. The sensitivity should be less than rated 12 dB SINAD specifications with an audio output of at least 6.0 Watts (6.9 Volts RMS across the 8.0-ohm receiver load using the Distortion Analyzer as a VTVM).
- F. Leave all controls as they are and all equipment connected if the Modulation Acceptance Bandwidth test is to be performed.

SERVICE CHECK

If the sensitivity level is more than rated 12 dB SINAD, check the alignment of the RF stages as directed in the Alignment Procedure, and make the gain measurements as shown on the Troubleshooting Procedure.

STEP 3 MODULATION ACCEPTANCE BANDWIDTH (IF BANDWIDTH)

If STEPS 1 and 2 check out properly, measure the bandwidth as follows:

- A. Set the Signal Generator output for twice the microvolt reading obtained in the 12-dB SINAD measurement.
- B. Set the RANGE control on the Distortion Analyzer in the SET LEVEL position (1000-Hz filter out of the circuit), and adjust the input LEVEL control for a +2 dB reading on the 30% range.
- C. While increasing the deviation of the Signal Generator, switch the RANGE control from SET LEVEL to distortion range until a 12-dB difference is obtained between the SET LEVEL and distortion range readings (from +2 dB to -10 dB).
- D. The deviation control reading for the 12-dB difference is the Modulation Acceptance Bandwidth of the receiver. It should be more than ± 7 kHz.

SERVICE CHECK

If the Modulation Acceptance Bandwidth test does not indicate the proper width, make gain measurements as shown on the Receiver Troubleshooting Procedure.

138-174 MHz 11.2 MHz

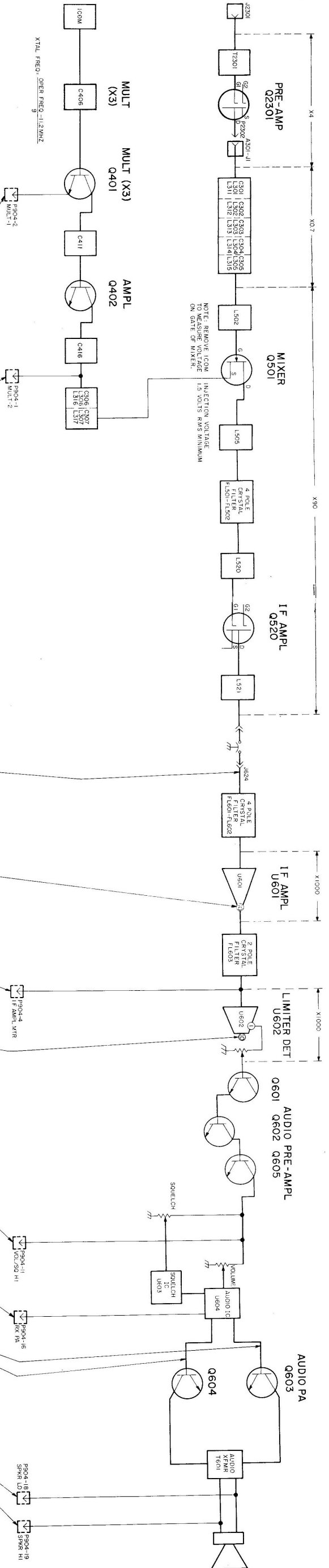

STEP 2-SIMPLIFIED GAIN CHECKS →

- EQUIPMENT REQUIRED:
1. VTVM - AC & DC
 2. SIGNAL GENERATOR (MEASUREMENTS 803 OR EQUIVALENT)
 3. RF VOLTMETER
- PRELIMINARY STEPS:
1. SET VOLUME CONTROL FOR 9.8 VOLTS ACROSS 8.0-0HM LOAD. IF THIS CANNOT BE OBTAINED, SET TO APPROX.
 2. SET OF MAX. GAIN POSITION FULLY COUNTERCLOCKWISE.
 3. RECEIVER SHOULD BE PROPERLY ALIGNED.
 4. CONNECT METER BETWEEN A- AND POINTS INDICATED BY ARROW.

SIGNAL GENERATOR INPUT AT A301-J1 MAINTAIN FM (5.8 VDC WHEN SIGNAL 1.0 VAC)	UNMODULATED	UNMODULATED	UNMODULATED	NO SIGNAL INPUT	STANDARD SIGNAL (1 MILLIVOLT AT 1000 HZ WITH 3.0 KHZ DEVIATION)	STANDARD SIGNAL	STANDARD SIGNAL	STANDARD SIGNAL
PROCEDURE	SET GENERATOR OUTPUT AT 1000 MICROVOLTS	INCREASE GENERATOR OUTPUT FROM ZERO TO 40 MICROVOLTS WITH RF VOLTMETER	INCREASE GENERATOR OUTPUT FROM ZERO TO 100 MICROVOLTS WITH PREAMP	SHOULD BE IN SATURATION AT ALL TIMES	VOLTMETER SHOULD BE APPROX 1.0 VAC	VOLTMETER SHOULD BE APPROX 0.18 VAC	VOLTMETER SHOULD BE APPROX 6.7 VAC	WITH SPEAKER DISCONNECT ED, CONNECT VTVM OR SCOPE ACROSS 8-0HM LOAD POINTS 18 AND 19 (P904-18)
READING	VTVM READING SHOULD BE APPROX 0.5 VDC	RF VOLTMETER READING SHOULD BE APPROX 200 MILLIVOLTS	VTVM READING SHOULD BE APPROX 0.2 VDC					9.8 VAC

STEP 1 - QUICK CHECKS

TEST SET CHECKS

These checks are typical voltage readings measured with GE Test Set Model 4EX3All in the Test 1 position, or Model 4EX8K12 in the 1-Volt position.

Metering Position	Reading With No Signal In	Reading with 1 Micro-volt Unmodulated
A (FM DET)	Approximately 0.38 VDC	
B (IF Amp)		0.2 VDC
C (Mult-1)	0.45 VDC	
D (Mult-2)	0.1 VDC	
J (Reg. +10 Volts at System Metering jack)	+10 VDC	

STEP 4-VOLTAGE RATIO READINGS →

EQUIPMENT REQUIRED:

1. RF VOLTMETER (SIMILAR TO BOONTON MODEL 91-CA OR MILLIVAC TYPE MV-18 C.
2. SIGNAL ON RECEIVER FREQUENCY (BELOW SATURATION). CORRECT FREQUENCY CAN BE DETERMINED BY AN FM DET READING OF 0.18VDC USE 1,000 HERTZ SIGNAL WITH 3.0 KHz DEVIATION.

PROCEDURE:

1. APPLY PROBE TO INPUT OF STAGE (FOR EXAMPLE, SOURCE OF RF AMP). PEAK RESONANT CIRCUIT OF STAGE BEING MEASURED AND TAKE VOLTAGE READING (E₁).
2. MOVE PROBE TO INPUT OF FOLLOWING STAGE (MIXER). REPEAK FIRST RESONANT CIRCUIT THEN PEAK CIRCUIT BEING MEASURED AND TAKE READINGS (E₂).
3. CONVERT READINGS BY MEANS OF THE FOLLOWING FORMULA.

$$\text{VOLTAGE RATIO} = \frac{E_2}{E_1}$$

4. CHECK RESULTS WITH TYPICAL VOLTAGE RATIOS SHOWN ON DIAGRAM.

SYMPTOM CHECKS

SYMPTOM	PROCEDURE
NO SUPPLY VOLTAGE	<ul style="list-style-type: none"> • Check power connections and continuity of supply leads, and check fuse. If fuse is blown, check receiver for short circuits.
NO REGULATED 10-VOLTS	<ul style="list-style-type: none"> • Check the 12-Volt supply. Then check 10-Volt regulator circuit. (See Troubleshooting Procedure for 10-Volt Regulator).
LOW 1ST LIM READING	<ul style="list-style-type: none"> • Check supply voltages and then check oscillator readings at P904-1 & -2 as shown in STEP 2A. • Make SIMPLIFIED VTVM GAIN CHECKS from Mixer through 1st Limiter stages as shown in STEP 2A.
LOW OSCILLATOR/MULTIPLIER READINGS	<ul style="list-style-type: none"> • Check alignment of Oscillator/Multiplier. (Refer to Front End Alignment Procedure). • Check voltage readings of Oscillator/Multiplier (Q401, Q402).
LOW RECEIVER SENSITIVITY	<ul style="list-style-type: none"> • Check Front End Alignment. (Refer to Receiver Alignment Procedure). • Check antenna connections, cable and antenna switch. • Check Oscillator injection voltage. • Check voltage readings of Mixer and IF Amp. • Make SIMPLIFIED GAIN CHECKS (STEP 2A).
IMPROPER SQUELCH OPERATION	<ul style="list-style-type: none"> • Check voltages on Schematic Diagram. • Make gain and waveform checks with noise. • Make gain and waveform checks with 6 kHz signal. • Check discrete components in the squelch circuit. • Replace IC circuit U603.
LOW OR DISTORTED AUDIO	<ul style="list-style-type: none"> • Check voltages on Schematic Diagram. • Make gain and waveform checks. • Check receiver and alignment and FM Detector output. • Check Q601 thru Q605 and other discrete components. • Replace IC circuit U604.

STEP 3-AUDIO & SQUELCH WAVEFORMS

EQUIPMENT REQUIRED:

1. OSCILLOSCOPE CONNECTED BETWEEN A- AND POINTS INDICATED BY ARROW.
2. SIGNAL GENERATOR (MEASUREMENTS MB03 OR EQUIVALENT).
3. 6 KHZ GENERATOR

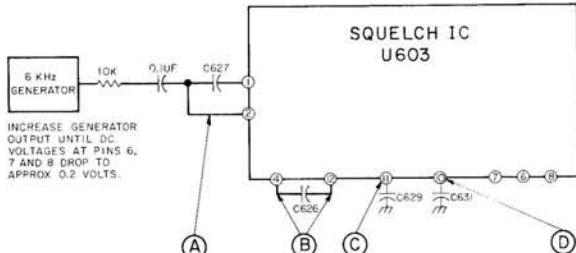

SQUELCH CIRCUIT CHECKS WITH 6 KHZ SIGNAL:

PRELIMINARY STEPS

1. QUIET RECEIVER WITH A 1000 MICROVOLT, UNMODULATED SIGNAL.
2. SET SQUELCH CONTROL TO APPROX MID-RANGE.
3. APPLY 6 KHZ SIGNAL TO PIN 1 AS SHOWN, AND CHECK WAVEFORMS (A) THRU (D).

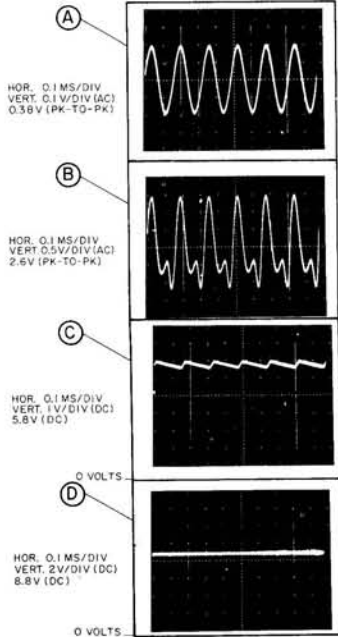

SQUELCH CIRCUIT CHECK WITH NOISE:

PRELIMINARY STEPS

1. NO INPUT SIGNAL APPLIED.
2. SET SQUELCH CONTROL FOR CRITICAL SQUELCH.
3. CHECK WAVEFORMS (A) THRU (D).

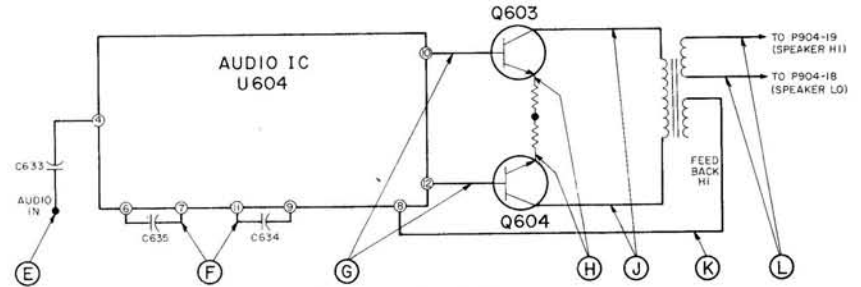
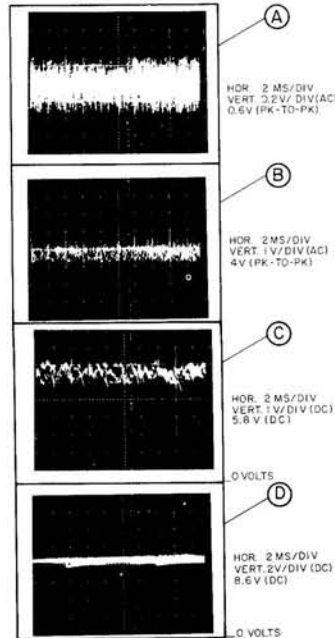

AUDIO CIRCUIT CHECK WITH STANDARD SIGNAL (1000 MICROVOLTS AT RECEIVER FREQ. MODULATED BY 1 KHZ WITH 3.0 KHZ DEVIATION)

PRELIMINARY STEPS

1. SET VOLUME CONTROL FOR 9.8 VOLTS ACROSS 8-OHM, 12 WATT LOAD.
2. SET SQUELCH CONTROL FULLY COUNTERCLOCKWISE.
3. CHECK WAVEFORMS (E) THRU (L).

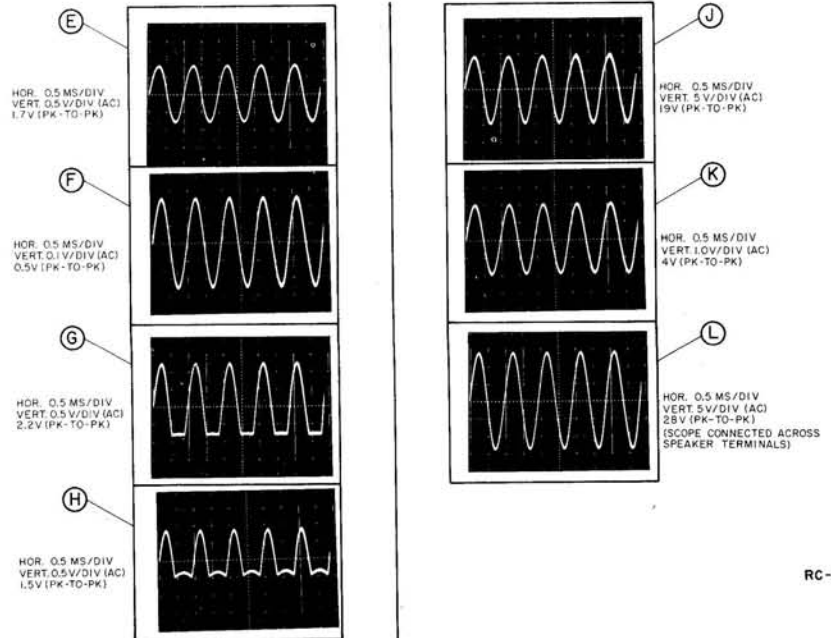

RC-2816

TROUBLESHOOTING PROCEDURE

138—174 MHz MASTR RECEIVER

Issue 1

5

FRONT END ALIGNMENT

EQUIPMENT

- Ge Test Set Models 4EX3A11, 4EX8K12, or 20,000 ohms-per-Volt Multimeter with a 1-Volt scale.
- A 138-174 MHz signal source.

PRELIMINARY CHECKS AND ADJUSTMENTS

- Connect black plug from Test Set to Receiver Centralized Metering Jack J601, and red plug to system board metering jack J905. Set meter sensitivity switch to the TEST 1 position (or 1-Volt position on 4EX8K12).
- For multi-frequency receivers with a frequency spacing up to 0.450 MHz for frequency range of 138-155 MHz, or 0.500 MHz for frequency range of 150.8-174 MHz, align the receiver on the channel nearest center frequency.

For multi-frequency receivers with a frequency spacing exceeding the above but no greater than .900 MHz for frequency range of 138-155 MHz, or 1.00 MHz for frequency range of 150.8-174 MHz, align the receiver using a center frequency tune-up ICOM. These limits can be extended to 1.60 MHz, and 1.80 MHz respectively, with 3 dB degradation in standard receiver specifications.
- With Test Set in Position J, check for regulated +10 Volts. If using Multimeter, measure between J905-3 (+) and J905-9 (-).
- If using Multimeter, connect the negative lead to J601-9 (A-).
- Disable Channel Guard.

ALIGNMENT PROCEDURE

STEP	METERING POSITION		TUNING CONTROL	METER READING	PROCEDURE
	GE Test Set	Multimeter - at J601-9			
OSCILLATOR/MULTIPLIER					
1.	C (MULT-1)	Pin 3	L401	Maximum	Tune L401 for maximum meter reading.
2.	D (MULT-2)	Pin 4	L402, L403, C306 and C307	See Procedure	Tune L402 and L403 for maximum meter reading. Next, tune C306 for a dip and C307 for a peak in meter reading. Then carefully tune L401, L402 and L403 for maximum meter reading, and tune C306 and C307 for a dip in meter reading.
RF SELECTIVITY					
3.	A (DISC)	Pin 2		Zero	Apply an on-frequency signal to the antenna jack. Adjust the signal generator for discriminator zero.
4.	B (IF AMP)	Pin 1	C502, C301 thru C305 (and T2301 if present)	Maximum	Apply an on-frequency signal to the antenna jack, keeping the signal below saturation. Then tune C502 and C301 through C305 for maximum meter reading. In receivers with the UHS pre-amplifier, also tune T2301 for maximum meter reading.
5.	B (IF AMP)	Pin 1	C502, C301 thru C305 (and T2301 if present)	Maximum	Apply an on-frequency signal to the antenna jack and slightly tune C502, C301 through C305 (and T2301 if present) for best quieting sensitivity.

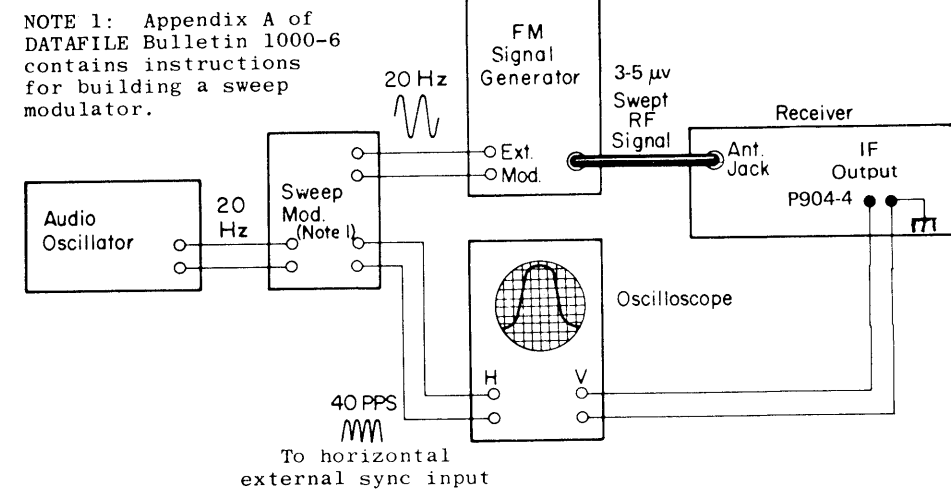
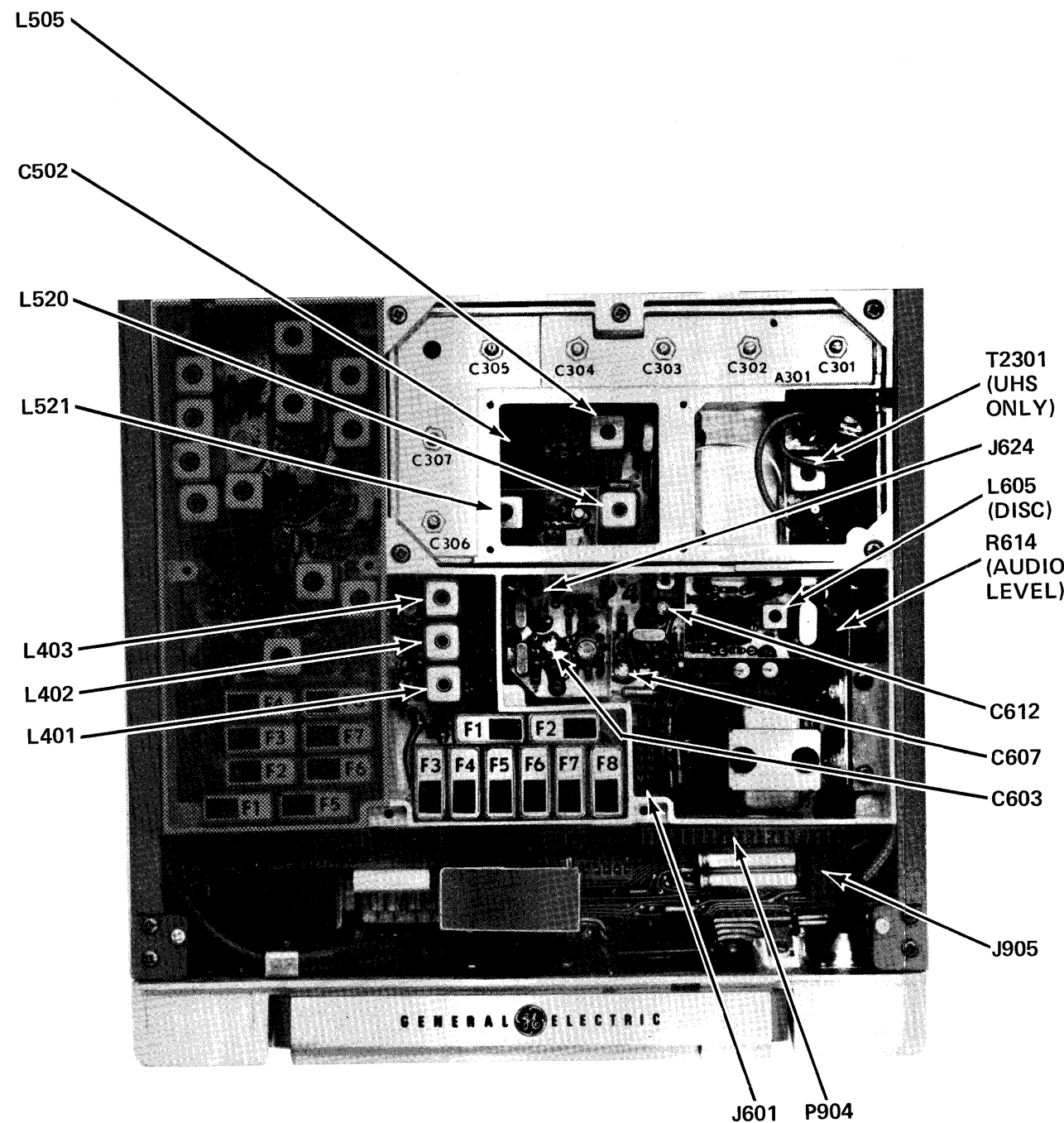

NOTE 1: Appendix A of DATAFILE Bulletin 1000-6 contains instructions for building a sweep modulator.

ICOM FREQUENCY ADJUSTMENT

First, check the frequency to determine if any adjustment is required. The frequency measurement requires equipment with an absolute accuracy which is 5 to 10 times better than the tolerance to be maintained. When performing frequency measurement, the entire radio should be as near as possible to an ambient temperature of 26.5°C (79.8°F).
MASTR II ICOMS should be reset only when the measured frequency error exceeds the following limits:
A. 20.5 PPM, when the radio is at 26.5°C (79.8°F).
B. 22 PPM at any other temperature within the range -5°C to +35°C (-23°F to +93°F).
C. The specification limit (22 PPM or 25 PPM) at any temperature within the ranges -40°C to -5°C (-40°F to +23°F) or +5°C to +70°C (+31°F to +158°F).

If frequency adjustment is required, lift up the cover on the top of the ICOM to expose the adjustment trimmer. Depending upon the type of frequency measuring equipment that is available, any of the following procedures may be used:

- DIRECT MEASUREMENT IN THE INJECTION CHAIN**
 - WITH A FREQUENCY COUNTER. "Count" the frequency at the junction of C415 and C417 on the Oscillator/Multiplier Board. The frequency at this point is 9 times the ICOM frequency. NOTE: The output from the ICOM itself is not sufficiently sinusoidal for reliable operation with most frequency counters.
 - WITH A COMMUNICATION MONITOR (for example: Cushman Model CE-3). "Monitor" frequency at the junction of C415 and C417 on the Oscillator/Multiplier Board. The frequency monitored at this point is 9 times the ICOM frequency. NOTE: This frequency will not always fall within an available measuring range of all monitors at all receiver operating frequencies.
- STANDARD "ON FREQUENCY" SIGNAL AT THE RECEIVER INPUT (Generated from a COMMUNICATION MONITOR, for example: Cushman Model CE-3).
 - WITH A FREQUENCY COUNTER. "Count" the developed IF frequency at the junction of C612 and L603 on the IFAS board. The deviation from the nominal IF frequency (11.2 MHz) in Hz is compared to the receiver operating frequency (also in Hz) to calculate error in PPM.
 - WITH AN 11.2 MHz IF FREQUENCY STANDARD (for example: General Electric Model 4E80A10). Loosely couple the IF frequency standard to the IF signal path to create a heterodyne with the developed IF frequency. The resultant "beat frequency" can be monitored by either of the following methods:

NOTE
To set ICOM frequency using "beat frequency" method, the temperature should be at 26.5°C (79.8°F). If the temperature is not 26.5°C, then offset the "ON FREQUENCY" signal (at the receiver input), as a function of actual temperature, by the frequency ERROR FACTOR (in PPM) shown in Figure 7.

- Audible "beat frequency" from the receiver speaker (this requires careful frequency adjustment of the frequency standard).
 - Observe "beat frequency" at P904-4 with an Oscilloscope.
 - With GE TEST SET (Meter Position B) connected to J601 on the IFAS Board, visually observe the "beat frequency" indicated by meter movement.
- The frequency of the "beat" is the frequency error, related to the IF frequency. This deviation, in Hz, is compared to the receiver operating frequency, also in Hz, to calculate the error in PPM.

NOTE
The Discriminator DC output (Meter Position A of the Test Set) is provided for routine test and measurement only. The limited resolution available (0.025 V per kHz as measured with GE Test Set in Meter Position A, or 0.1 V per kHz as measured with a VTVM at P904-3 or J601-2 on the IFAS board) is inadequate for oscillator frequency setting.

If the radio is at an ambient temperature of 26.5°C (79.8°F), set the oscillator for the correct mixer frequency (ICOM PART X 9).
If the radio is not at an ambient temperature of 26.5°C, setting errors can be minimized as follows:
A. To hold setting error to 40.6 PPM (which is considered reasonable for 5 PPM ICOMS):
1. Maintain the radio at 26.5°C (79.8°F) and set the oscillator to required mixer injection frequency, or
2. Maintain the radio at 26.5°C (79.8°F) and offset the oscillator, as a function of actual temperature, by the frequency error factor shown in Figure 7.
B. To hold setting error to 20.3 PPM (which is considered reasonable for 2 PPM ICOMS): Maintain the unit at 26.5°C (79.8°F) and offset the oscillator, as a function of actual temperature, by the frequency error factor shown in Figure 7.
For example: Assume the ambient temperature of the radio is 18.5°C (65.4°F). At that temperature, the curve shows a correction factor of 0.3 PPM. (At 138 MHz, 1 PPM is 138 Hz. At 174 MHz, 1 PPM is 174 Hz).
With a mixer injection frequency of 150 MHz, adjust the oscillator for a corrected mixer injection frequency 45 Hz (0.3 x 150 Hz) higher. If a negative correction factor is obtained (at temperatures above 26.5°C), set the oscillator for the indicated PPM lower than the calculated mixer injection frequency.

DEGREES FAHRENHEIT

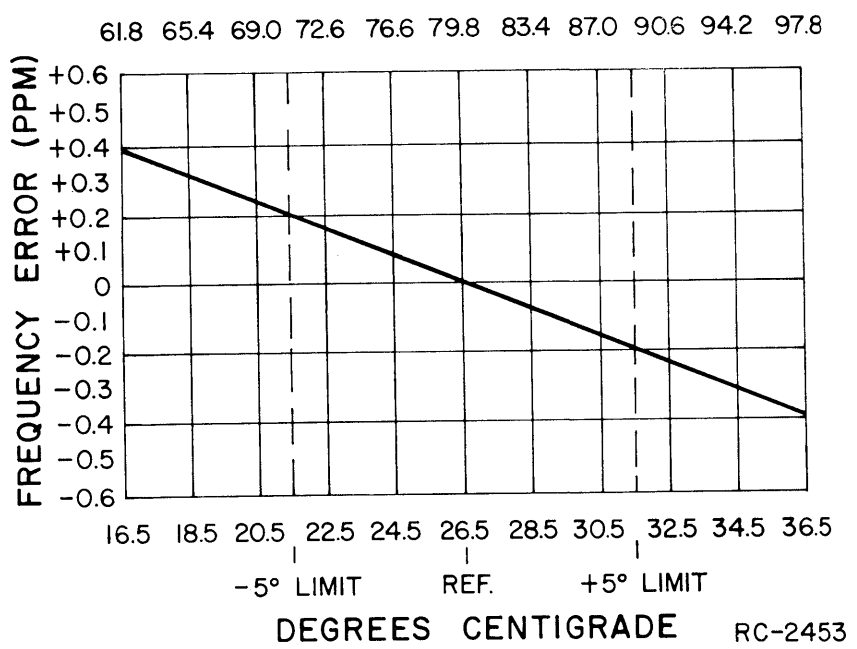

Figure 7 - Frequency Characteristics Vs. Temperature

COMPLETE RECEIVER ALIGNMENT

EQUIPMENT REQUIRED

- GE Test Models 4EX3A11, 4EX8K12 (or 20,000 ohms-per-Volt Multimeter with a 1-Volt scale).
- An 11.2 MHz signal source (GE Test Set Model 4EX9A10). Also a 138-174 MHz signal source (Measurements 803) with a one-inch piece of insulated wire no larger than .065 inch diameter connected to generator probe.
- A VTVM.

PRELIMINARY CHECKS AND ADJUSTMENTS

- Connect the black plug from the Test Set to receiver metering jack J601, and the red plug to system board metering jack J905. Set the meter sensitivity switch to the Test 1 (or 1-Volt position on the 4EX8K12).
- For multi-frequency receivers with a frequency spacing up to 0.450 MHz for frequency range of 138-155 MHz, or 0.500 MHz for frequency range of 150.8-174 MHz, align the receiver on the channel nearest center frequency.

For multi-frequency receivers with a frequency spacing exceeding the above but no greater than .900 MHz for frequency range of 138-155 MHz, or 1.00 MHz for frequency range of 150.8-174 MHz, align the receiver using a center frequency tune-up ICOM. These limits can be extended to 1.60 MHz, and 1.80 MHz respectively, with 3 dB degradation in standard receiver specifications.
- With the Test Set in Position J, check for regulated +10 Volts. With multimeter, measure from J905-3 to J905-9.
- If using Multimeter, connect the negative lead to J601-9 (A-).
- Disable the Channel Guard.

ALIGNMENT PROCEDURE

STEP	METERING POSITION		TUNING CONTROL	METER READING	PROCEDURE
	GE Test Set	Multimeter - at J601-9			
DISCRIMINATOR					
1.	A (DISC)	Pin 2	L605	Zero	Apply the correct IF signal between J624 and A-, and tune L605 for zero meter reading.
2.	A (DISC)	Pin 2	R614	1 Volt RMS	Remove the Test set metering plug from J601. Apply a 1000 microvolt signal with 1 kHz modulation and 3.0 kHz deviation to the antenna jack. Set R614 for 1 Volt RMS measured with a VTVM at P904-11 (VOL/SQ HI) and P904-17 (A-).
3.	C (MULT-1)	Pin 3	L401	Maximum	Re-connect the Test set metering plug to J601. Tune L401 for maximum meter reading.
4.	D (MULT-2)	Pin 4	L402, L403, C306 and C307	See Procedure	Tune L402 and L403 for maximum meter reading. Next, tune C306 for a dip and C307 for a peak in meter reading. Then carefully tune L401, L402 and L403 for maximum meter reading, and tune C306 and C307 for a dip in meter reading.
RF SELECTIVITY					
5.	A (DISC)	Pin 2		Zero	Apply an on-frequency signal in the hole adjacent to C305. Adjust the signal generator for discriminator zero.
6.	B (IF AMP)	Pin 1	C502	Maximum	Apply the signal as in Step 5 and tune C502 for maximum meter reading.
7.	B (IF AMP)	Pin 1	C305	Maximum	Apply an on-frequency signal in the hole adjacent to C304, keeping the signal below saturation. Then tune C305 for maximum meter reading.
8.	B (IF AMP)	Pin 1	C304	Maximum	Apply an on-frequency signal in the hole adjacent to C303, keeping the signal below saturation. Then tune C304 for maximum meter reading.
9.	B (IF AMP)	Pin 1	C303	Maximum	Apply an on-frequency signal in the hole adjacent to C302, keeping the signal below saturation. Then tune C303 for maximum meter reading.
10.	B (IF AMP)	Pin 1	C302 and C301	Maximum	Apply an on-frequency signal to the antenna jack, keeping the signal below saturation. Then tune C302 and C301 for maximum meter reading.
11.	B (IF AMP)	Pin 1	C502, C301 thru C305 (and T2301 if present)	Maximum	Apply an on-frequency signal to the antenna jack, keeping the signal below saturation. Then tune C502 and C301 through C305 for maximum meter reading. In receivers with the UHS pre-amplifier, also tune T2301 for maximum meter reading.
12.	B (IF AMP)	Pin 1	C502, C301 thru C305 (and T2301 if present)	Maximum	Apply an on-frequency signal to the antenna jack and slightly tune C502, C301 through C305 (and T2301 if present) for best quieting sensitivity.
MIXER & IF					
The mixer and IF circuits have been aligned at the factory and will normally require no further adjustment. If adjustment is necessary, use the procedure outlined in STEP 13.					
NOTE					
Refer to DATAFILE BULLETIN 1000-6 (IF Alignment of Two-Way Radio FM Receivers) for helpful suggestions on how to determine when IF Alignment is required.					
13.			L504, L520, C521, C601, C603, C607 and C612		Connect scope, signal generator, and probe as shown in Figure 6. Set signal generator level for 3 to 5 uV and modulate with 10 kHz at 20 Hz. With probe between P904-4 (or J601-1) and A-, tune L505, L520, L521, C521, C601, C603, C607 and C612 for double trace as shown on scope pattern.
14.	A	Pin 2		See Procedure	Check to see that discriminator idling voltage is within ±.05 Volt of zero with no signal applied. Check to see that modulation acceptance bandwidth is greater than 26.5 kHz.

ALIGNMENT PROCEDURE

138-174 MHz MASTR RECEIVER
Issue 4

Figure 6 - Test Setup for 20-Hz Double-Trace Sweep Alignment

STEP 1 - QUICK CHECKS

TEST SET CHECKS

These checks are typical voltage readings measured with GE Test Set Model 4EX3A11 in the Test 1 position, or Model 4EX3K12 in the 1-Volt position.

Metering Position	Reading With No Signal In	Reading with 4 Micro-volt Unmodulated
A (Disc Idling)	Less than ±0.05 VDC	
B (IF Amp)		0.2 VDC
C (Mult-1)	0.2 VDC	
D (Mult-2)	0.4 VDC	
J (Reg. +10 Volts at System Metering Jack)	+10 VDC	

SYMPTOM CHECKS

SYMPTOM	PROCEDURE
NO SUPPLY VOLTAGE	<ul style="list-style-type: none"> Check power connections and continuity of supply leads, and check fuse in power supply. If fuse is blown, check receiver for short circuits.
NO REGULATED 10-VOLTS	<ul style="list-style-type: none"> Check the 12-Volt supply. Then check 10-Volt regulator circuit. (See Troubleshooting Procedure for 10-Volt Regulator).
LOW 1ST LIM READING	<ul style="list-style-type: none"> Check supply voltages and then check oscillator readings at P904-1 & -2 as shown in STEP 2. Make SIMPLIFIED VTM GAIN CHECKS from Mixer through 1st Limiter stages as shown in STEP 2.
LOW OSCILLATOR/MULTIPLIER READINGS	<ul style="list-style-type: none"> Check alignment of Oscillator/Multiplier chain. (Refer to Front End Alignment Procedure). Check voltage readings of Oscillator/Multiplier chain (Q401, Q402, Q403).
LOW RECEIVER SENSITIVITY	<ul style="list-style-type: none"> Check Front End Alignment. (Refer to Receiver Alignment Procedure). Check antenna connections, cable and antenna switch. Check Oscillator injection voltage. Check voltage readings of Mixer and IF Amp. Make SIMPLIFIED GAIN CHECKS (STEP 2).
IMPROPER SQUELCH OPERATION	<ul style="list-style-type: none"> Check voltages on Schematic Diagram. Make gain and waveform checks with noise. Make gain and waveform checks with 6 kHz signal. Check discrete components in the squelch circuit. Replace IC circuit U603.
LOW OR DISTORTED AUDIO	<ul style="list-style-type: none"> Check voltages on Schematic Diagram. Make gain and waveform checks. Check receiver and alignment and discriminator output. Check Q601, Q602 and other discrete components. Replace IC circuit U604.
DISCRIMINATOR IDLING TOO FAR OFF ZERO	<ul style="list-style-type: none"> See if discriminator zero is in center of IF bandpass.

STEP 4-VOLTAGE RATIO READINGS

EQUIPMENT REQUIRED:
 1. RF VOLTMETER (SIMILAR TO BOONTON MODEL 91-CA OR MILLIVAC TYPE MV-18-C).
 2. SIGNAL ON RECEIVER FREQUENCY (BELOW SATURATION). CORRECT FREQUENCY CAN BE DETERMINED BY ZEROING THE DISCRIMINATOR. USE 1000 HERTZ SIGNAL WITH 3.0 KHZ DEVIATION.
PROCEDURE:
 1. APPLY PROBE TO INPUT OF STAGE (FOR EXAMPLE, SOURCE OF RF AMP). PEAK RESONANT CIRCUIT OF STAGE BEING MEASURED AND TAKE VOLTAGE READING (E1).
 2. MOVE PROBE TO INPUT OF FOLLOWING STAGE (MIXER). DEBACK FIRST RESONANT CIRCUIT THEN PEAK CIRCUIT BEING MEASURED AND TAKE READING (E2).
 3. CONVERT READINGS BY MEANS OF THE FOLLOWING FORMULA. VOLTAGE RATIO = $\frac{E2}{E1}$
 4. CHECK RESULTS WITH TYPICAL VOLTAGE RATIOS SHOWN ON DIAGRAM.

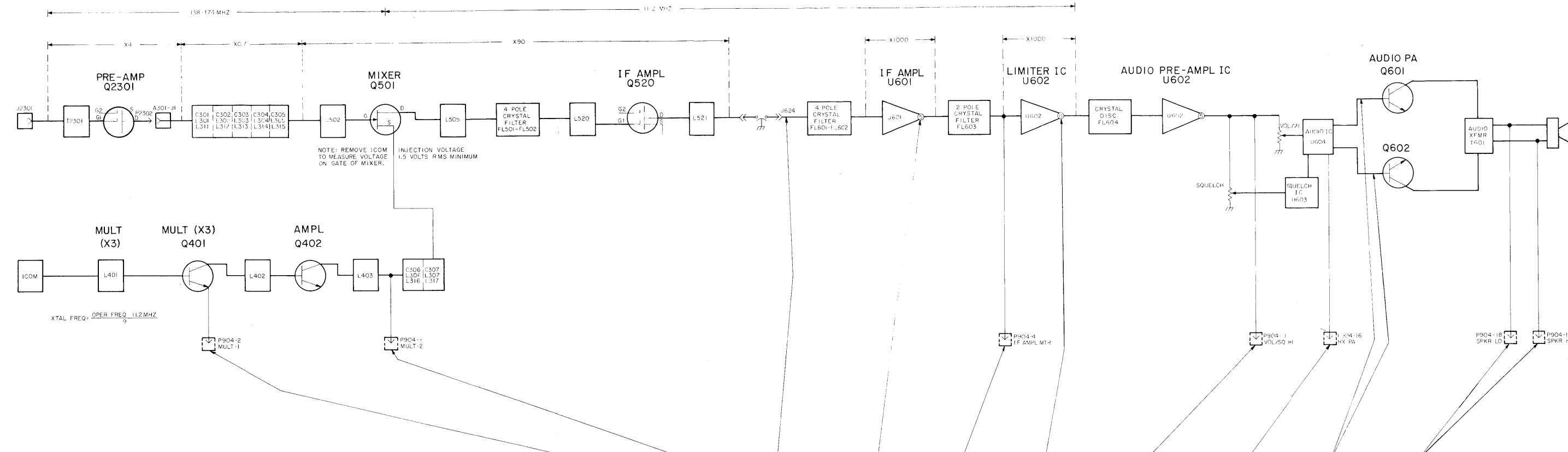

STEP 2-SIMPLIFIED GAIN CHECKS

EQUIPMENT REQUIRED:
 1. VTM-AC & DC
 2. SIGNAL GENERATOR (MEASUREMENTS B03 OR EQUIVALENT).
 3. RF VOLTMETER
PRELIMINARY STEPS:
 1. SET VOLUME CONTROL FOR 9.8 VOLTS ACROSS R0-0HM LOAD. IF THIS CANNOT BE OBTAINED, SET TO APPROX. 70% OF MAX ROTATION.
 2. SET SQUELCH CONTROL FULLY COUNTERCLOCKWISE.
 3. RECEIVER SHOULD BE PROPERLY ALIGNED.
 4. CONNECT METER BETWEEN A- AND POINTS INDICATED BY ARROW.

PROCEDURE	UNMODULATED	UNMODULATED	UNMODULATED	NO SIGNAL INPUT	STANDARD SIGNAL (1 MILLI-VOLT AT RECEIVER INPUT, UNMODULATED BY 1 KHZ, WITH 3.0 KHZ DEVIATION)	STANDARD SIGNAL	STANDARD SIGNAL	STANDARD SIGNAL
READING	SET GENERATOR OUTPUT AT 1000 MICROVOLTS	INCREASE GENERATOR OUTPUT FROM 250 TO 100 MICROVOLTS	INCREASE GENERATOR OUTPUT FROM 100 TO 10 MICROVOLTS	SHOULD BE IN SATURATION AT ALL TIMES				WITH SPEAKER DISCONNECTED, CONNECT VTM OR SCOPE ACROSS R-0HM (VAD) TERMINALS BETWEEN P904-18 AND P904-19
	VTM READING SHOULD BE APPROX 0.3 VDC	VTM READING SHOULD BE APPROX 0.4 VDC	RF VOLTMETER READING SHOULD BE APPROX 200 MILLIVOLTS		VTM READING SHOULD BE APPROX 1.0 VAC	VTM READING SHOULD BE APPROX 0.18 VAC	VTM READING SHOULD BE APPROX 6.7 VAC	9.8 VAC

STEP 3-AUDIO & SQUELCH WAVEFORMS

EQUIPMENT REQUIRED:
 1. OSCILLOSCOPE CONNECTED BETWEEN A- AND POINTS INDICATED BY ARROW.
 2. SIGNAL GENERATOR (MEASUREMENTS M03 OR EQUIVALENT).
 3. 6 KHZ GENERATOR

SQUELCH CIRCUIT CHECKS WITH 6 KHZ SIGNAL:

PRELIMINARY STEPS:
 1. QUIET RECEIVER WITH A 1000 MICROVOLT UNMODULATED SIGNAL.
 2. SET SQUELCH CONTROL TO APPROX MID RANGE.
 3. APPLY 6 KHZ SIGNAL TO PIN 1 AS SHOWN, AND CHECK WAVEFORMS (A) THRU (D).

SQUELCH CIRCUIT CHECK WITH NOISE:

PRELIMINARY STEPS:
 1. NO INPUT SIGNAL APPLIED.
 2. SET SQUELCH CONTROL FOR CRITICAL SQUELCH.
 3. CHECK WAVEFORMS (E) THRU (H).

AUDIO CIRCUIT CHECK WITH STANDARD SIGNAL (1000 MICROVOLTS AT RECEIVER FREQUENCY, MODULATED BY 1 KHZ WITH 3.0 KHZ DEVIATION)

PRELIMINARY STEPS:
 1. SET VOLUME CONTROL FOR 9.8 VOLTS ACROSS R-0HM, 12 WATT LOAD.
 2. SET SQUELCH CONTROL FULLY COUNTERCLOCKWISE.
 3. CHECK WAVEFORMS (I) THRU (L).

TROUBLESHOOTING PROCEDURE

138-174 MHz MASTR RECEIVER

RF ASSEMBLY
BOTTOM VIEW

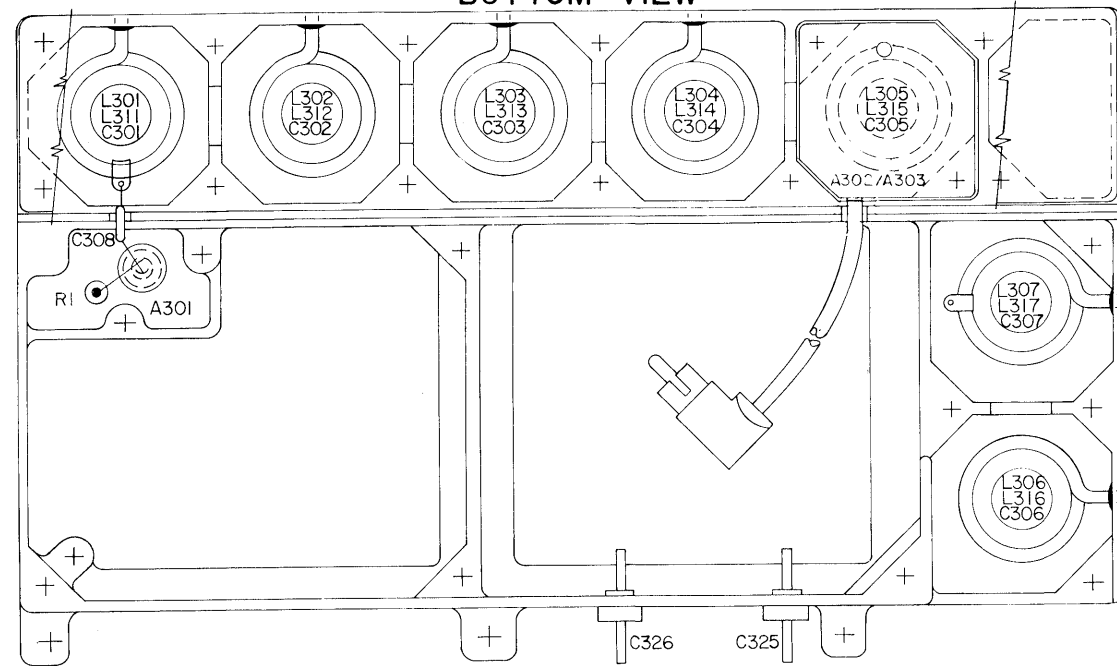

RECEIVER WITH
UHS PRE-AMPLIFIER

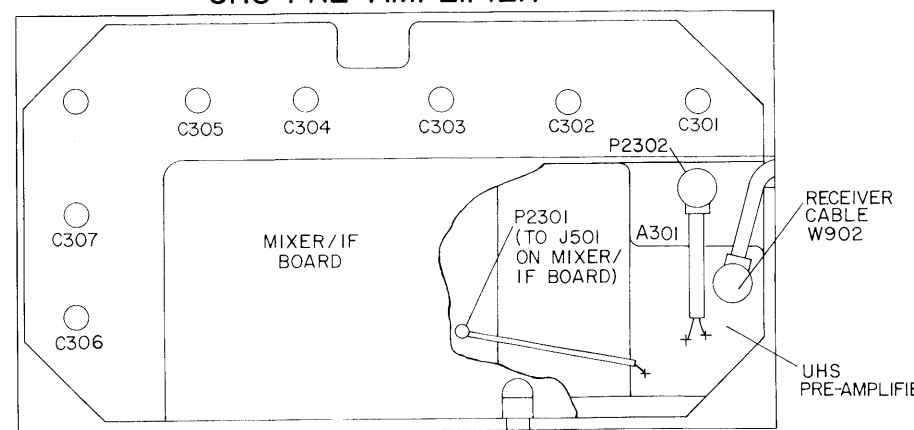

UHS PRE-AMPLIFIER

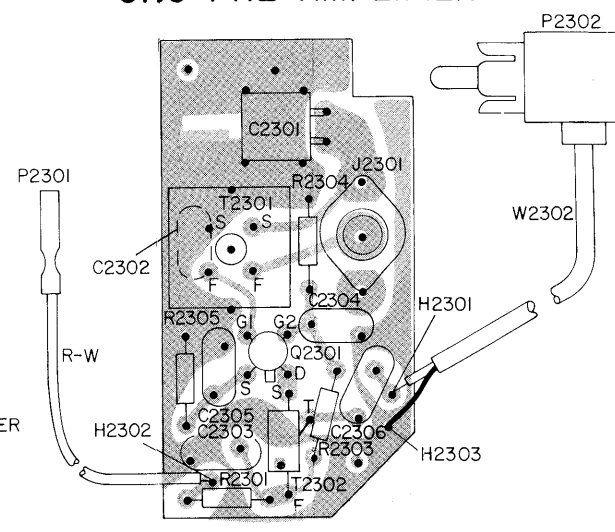

(19C320201, Sh. 2, Rev. 1)
(19C320201, Sh. 3, Rev. 1)

COMPONENT SIDE

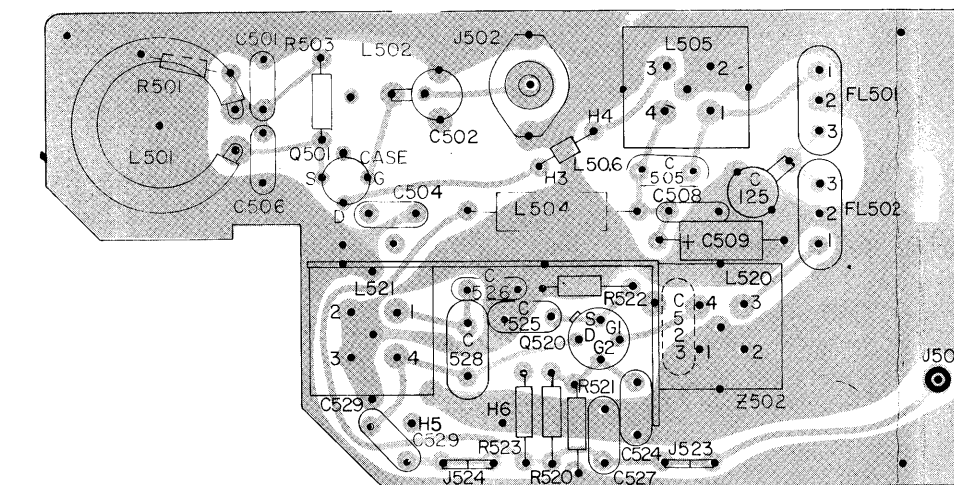

(19C321054, Sh. 2, Rev. 1)
(19C321054, Sh. 3, Rev. 0)

MIXER/IF BOARD

SOLDER SIDE

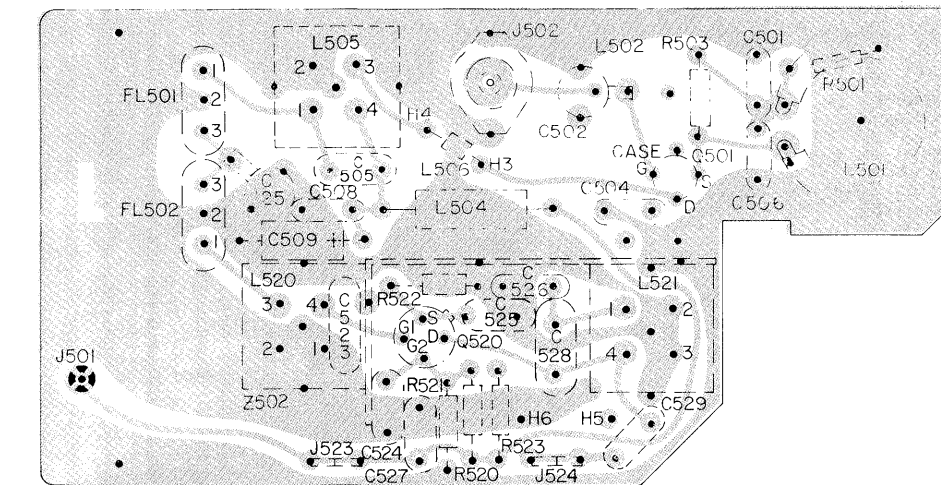

(19C321054, Sh. 2, Rev. 1)

FET IDENTIFICATION



VIEW FROM LEAD END

A301
ANT INPUT

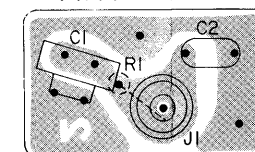

(19E21979, Sh. 2, Rev. 2)
(19E21979, Sh. 3, Rev. 2)

STANDARD RECEIVER

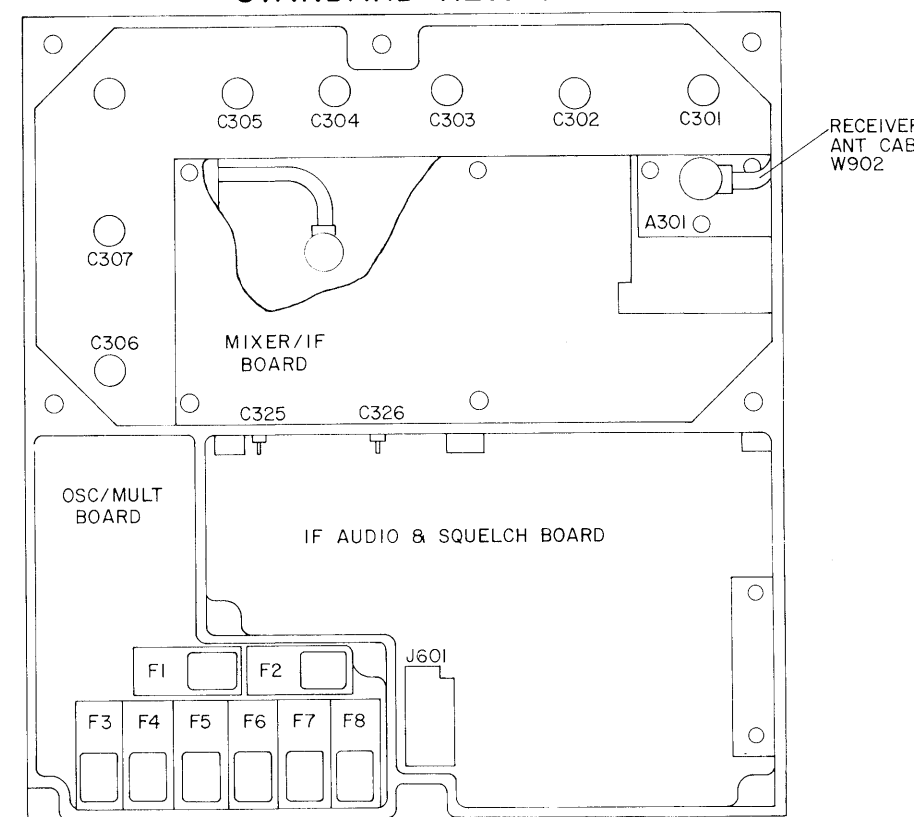

OSC/MULT BOARD

SOLDER SIDE

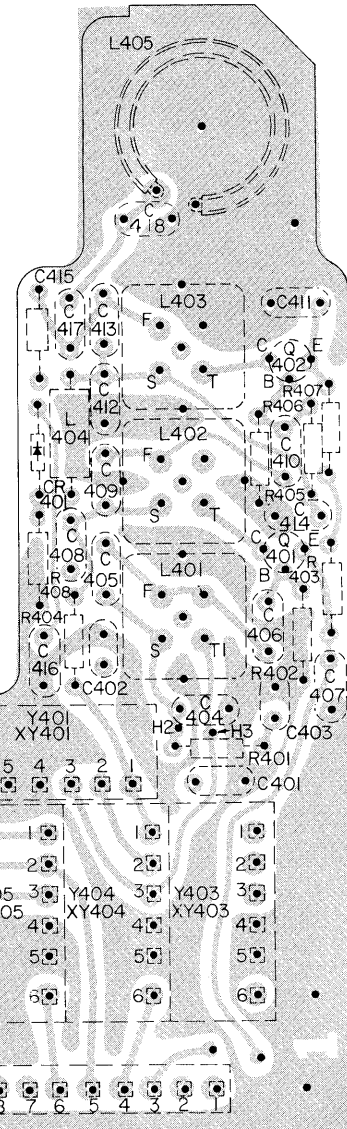

(19D416577, Sh. 2, Rev. 1)
(19D416577, Sh. 3, Rev. 1)

COMPONENT SIDE

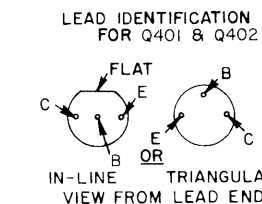
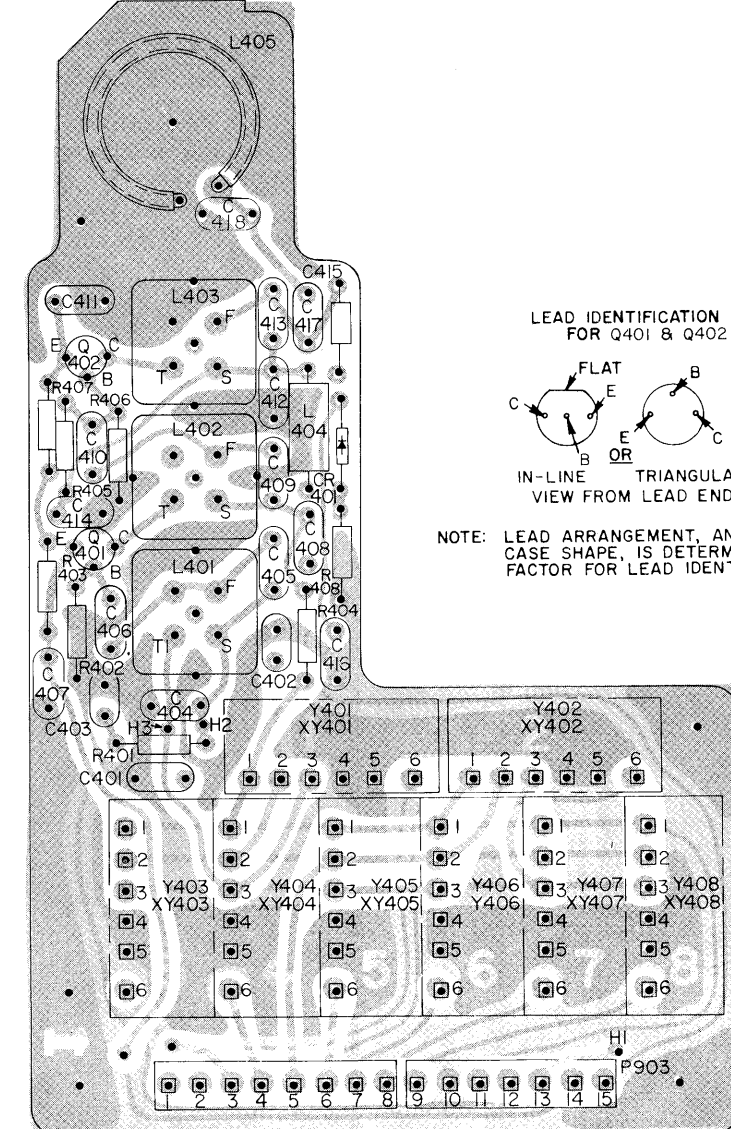

NOTE: LEAD ARRANGEMENT, AND NOT CASE SHAPE, IS DETERMINING FACTOR FOR LEAD IDENTIFICATION

(19D416577, Sh. 2, Rev. 1)
(19D416577, Sh. 3, Rev. 1)

COMPONENT SIDE

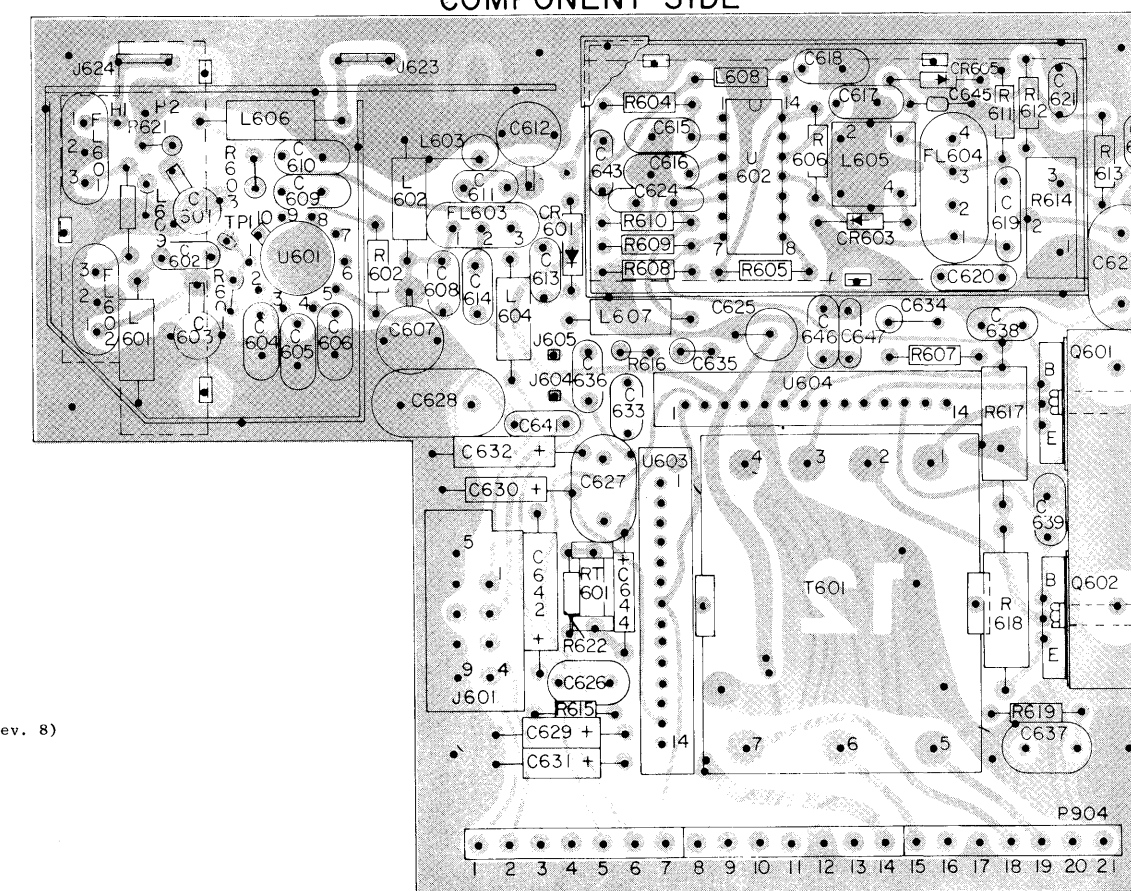

(19R622042, Rev. 8)

IF/AUDIO & SQUELCH BOARD

SOLDER SIDE

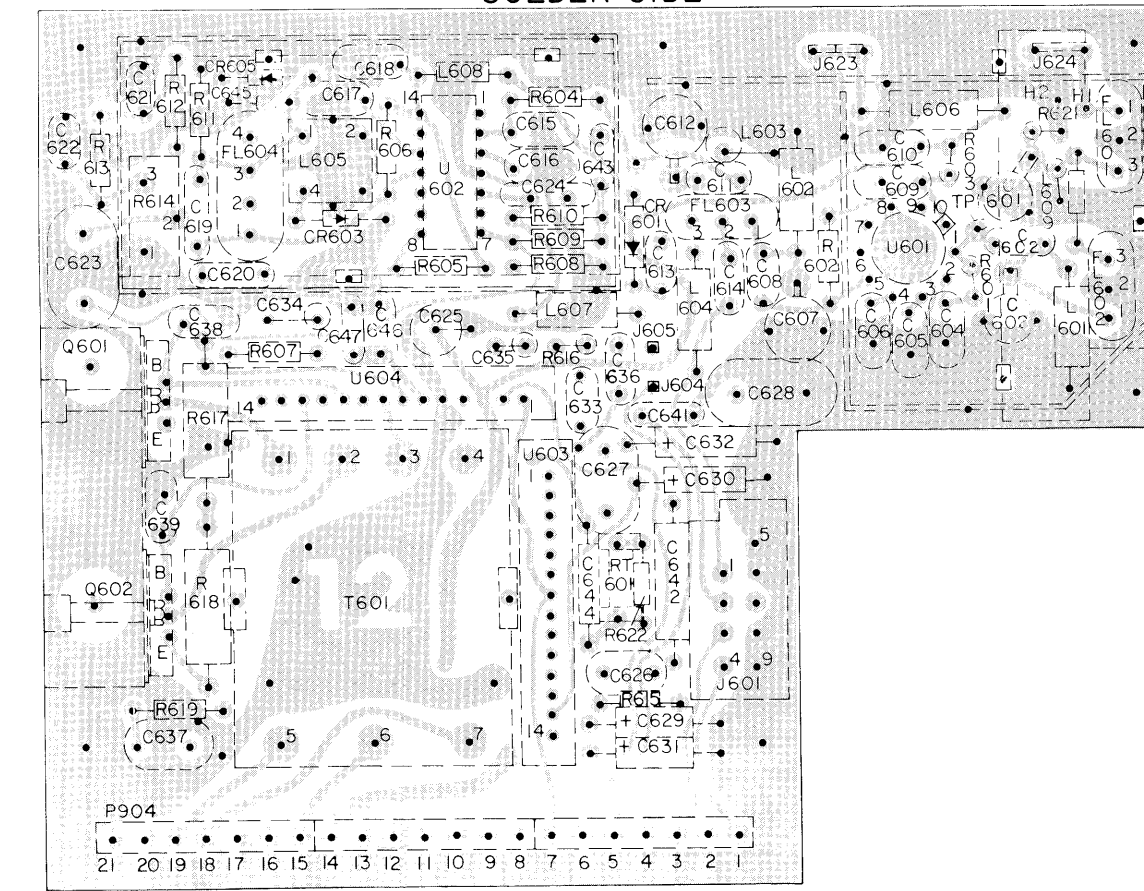

(19C320184, Sh. 1, Rev. 10)
(19C320184, Sh. 2, Rev. 12)

(19C320184, Sh. 2, Rev. 12)

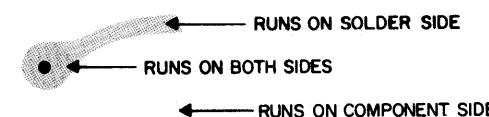

OUTLINE DIAGRAM
138—174 MHz MASTR RECEIVER

PARTS LIST

LBI-4534C
138-174 MHz RECEIVER RF ASSEMBLY
MIXER IF, OSCILLATOR-MULTIPLIER AND
UHS PRE-AMPLIFIER

Table with columns: SYMBOL, GE PART NO., DESCRIPTION. Contains parts for RF ASSEMBLY, COMPONENT BOARD, CAPACITORS, JACKS AND RECEPTACLES, RESISTORS, INDUCTORS, COILS, CABLES, TERMINALS, FILTERS, JACKS AND RECEPTACLES, CAPACITORS, INDUCTORS, TRANSISTORS, TRANSFORMERS, CAPACITORS, SOCKETS, COIL ASSEMBLY.

Table with columns: SYMBOL, GE PART NO., DESCRIPTION. Contains parts for MIXER-IF BOARD, CAPACITORS, JACKS AND RECEPTACLES, RESISTORS, INDUCTORS, COILS, CABLES, TERMINALS, FILTERS, JACKS AND RECEPTACLES, CAPACITORS, INDUCTORS, TRANSISTORS, TRANSFORMERS, CAPACITORS, SOCKETS, COIL ASSEMBLY.

Table with columns: SYMBOL, GE PART NO., DESCRIPTION. Contains parts for COIL ASSEMBLY, CAPACITORS, INDUCTORS, TRANSISTORS, TRANSFORMERS, CAPACITORS, SOCKETS, COIL ASSEMBLY.

Table with columns: SYMBOL, GE PART NO., DESCRIPTION. Contains parts for COIL ASSEMBLY, CAPACITORS, INDUCTORS, TRANSISTORS, TRANSFORMERS, CAPACITORS, SOCKETS, COIL ASSEMBLY.

Table with columns: SYMBOL, GE PART NO., DESCRIPTION. Contains parts for OSCILLATORS, CAPACITORS, INDUCTORS, TRANSISTORS, TRANSFORMERS, CAPACITORS, SOCKETS, COIL ASSEMBLY.

Table with columns: SYMBOL, GE PART NO., DESCRIPTION. Contains parts for INDUCTORS, CAPACITORS, MISCELLANEOUS, DIODES AND RECTIFIERS, RESISTORS, JACKS AND RECEPTACLES, PLUGS, TRANSISTORS, TRANSFORMERS, CAPACITORS, SOCKETS, COIL ASSEMBLY.

PRODUCTION CHANGES

Changes in the equipment to improve performance or to simplify circuits are identified by a "Revision Letter", which is stamped after the model number of the unit. The revision stamped on the unit includes all previous revisions. Refer to the Parts List for descriptions of parts affected by these revisions.

REV. A - RF Assembly Mixer/IF Board incorporated into initial shipment.

REV. B - To improve the IF frequency response. Changed C521.

REV. C - To improve operation of MIF Board (improve intermodulation performance). Added C502, R503 and Z502. Deleted C503, L503, Z501. Changed C504, J502, R501, Q501 and L505.

REV. A - RF PRE-AMPLIFIER 19C320215G1.2 To increase Pre-Amplifier gain. Changed R2304.

REV. B - To increase Pre-Amplifier gain. Changed R2305.

*COMPONENTS ADDED, DELETED OR CHANGED BY PRODUCTION CHANGES

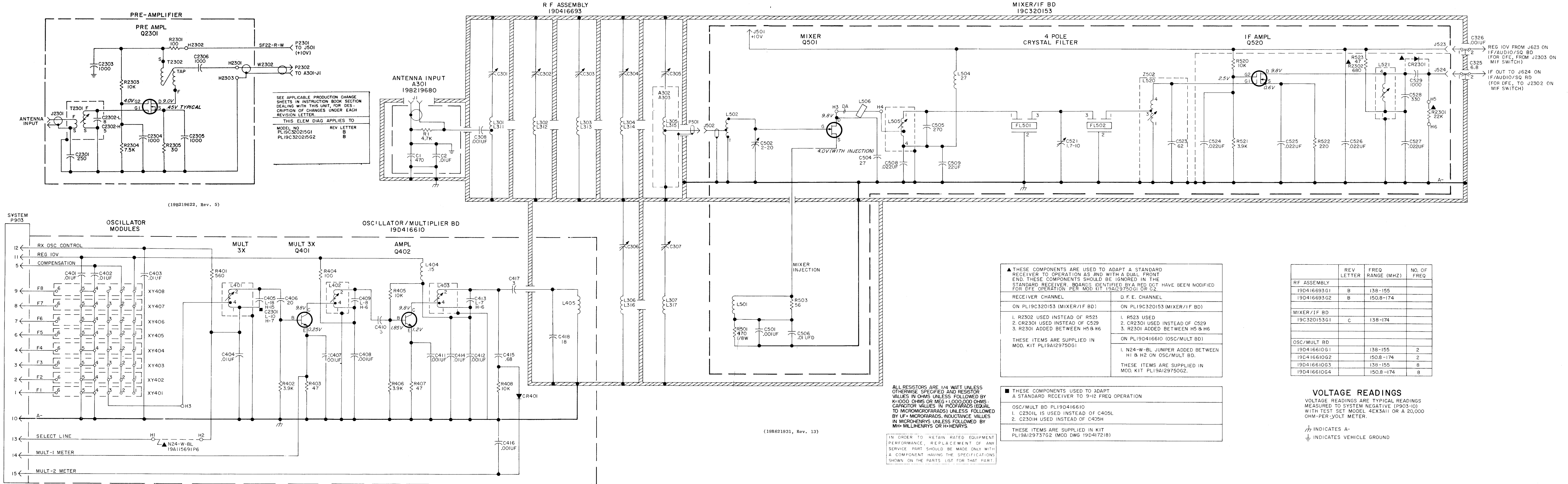

SCHEMATIC DIAGRAM
138-174 MHz, RF ASSEMBLY,
OSC/MULT, MIXER/IF AND
UHS PRE-AMPLIFIER BOARDS

IF/AUDIO/SQUELCH BD
19D416606

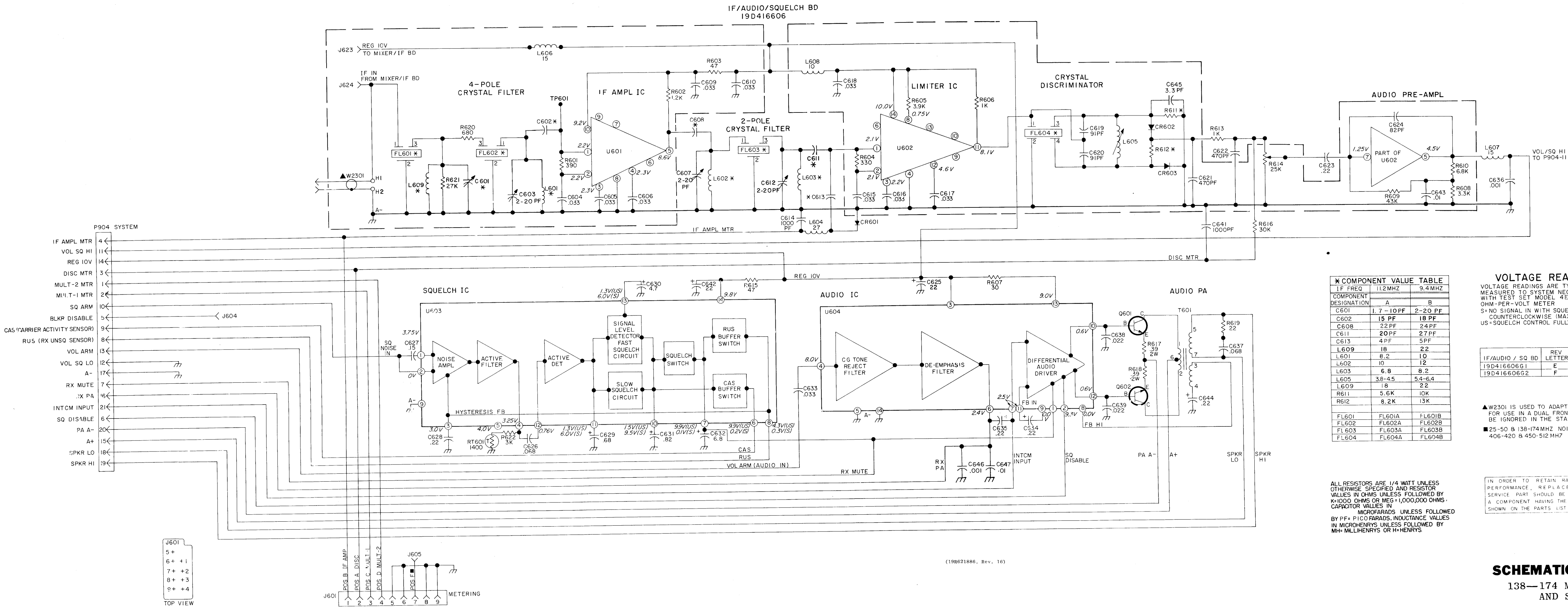

*** COMPONENT VALUE TABLE**

COMPONENT DESIGNATION	A	B
C601	1.7 - 10PF	2-20 PF
C602	15 PF	18 PF
C608	22 PF	24 PF
C611	20PF	27PF
C613	4PF	5PF
L609	18	22
L601	6.2	10
L602	10	12
L603	6.8	8.2
L605	3.8-4.5	5.4-6.4
L609	18	22
R611	5.6K	10K
R612	8.2K	13K

IF/AUDIO / SQ BD	REV LETTER	IF FREQ (MHZ)
19D416606G1	E	11.2
19D416606G2	F	9.4

FL601	FL601A	FL601B
FL602	FL602A	FL602B
FL603	FL603A	FL603B
FL604	FL604A	FL604B

VOLTAGE READINGS
VOLTAGE READINGS ARE TYPICAL READINGS MEASURED TO SYSTEM NEGATIVE (P904-I7) WITH TEST SET MODEL 4EX3111 OR A 20,000 OHM-PER-VOLT METER
S=NO SIGNAL IN WITH SQUELCH CONTROL FULLY COUNTERCLOCKWISE (MAXIMUM SQUELCH)
US=SQUELCH CONTROL FULLY CLOCKWISE

ALL RESISTORS ARE 1/4 WATT UNLESS OTHERWISE SPECIFIED AND RESISTOR VALUES IN OHMS UNLESS FOLLOWED BY K=1000 OHMS OR MEG=1,000,000 OHMS. CAPACITOR VALUES IN MICROFARADS UNLESS FOLLOWED BY PF= PICO FARADS. INDUCTANCE VALUES IN MICROHENRYS UNLESS FOLLOWED BY MH= MILLIHENRYS OR H=HENRYS.

IN ORDER TO RETAIN RATED EQUIPMENT PERFORMANCE, REPLACEMENT OF ANY SERVICE PART SHOULD BE MADE ONLY WITH A COMPONENT HAVING THE SPECIFICATIONS SHOWN ON THE PARTS LIST FOR THAT PART.

(19R621886, Rev. 16)

SCHEMATIC DIAGRAM
138-174 MHz, IF AUDIO AND SQUELCH BOARD

PARTS LIST
LBI-4443E
IF AUDIO AND SQUELCH BOARD
19D41660G1, G2

SYMBOL	GE PART NO.	DESCRIPTION
----- CAPACITORS -----		
C601A*	19B209351P1	Variable: 1.7 to 10 pf, 200 VDCW; sim to Matsushita ECV-1Z10P32.
	5491601P127	Phenolic: 2.4 pf ±5%, 500 VDCW.
C601B*	19B209351P2	Variable: 2.3 to 20 pf, 200 VDCW; sim to Matsushita ECV-1Z20P32.
	5491601P128	Phenolic: 2.7 pf ±5%, 500 VDCW.
C602A*	19A116656P15J0	Ceramic, disc: 15 pf ±5%, temp coef 0 PPM.
	19A116656P8J0	Ceramic, disc: 8 pf ±0.5 pf, temp coef 0 PPM.
C602B*	19A116656P18J0	Ceramic, disc: 18 pf ±5%, 500 VDCW, temp coef 0 PPM.
	19A116656P13J0	Ceramic, disc: 13 pf ±5%, 500 VDCW, temp coef 0 PPM.
C603*	19B209351P2	Variable: 2.3 to 20 pf, 200 VDCW, temp coef -350 +500 PPM; sim to Matsushita ECV-1Z20P32.
	19B209351P1	Variable: 1.7 to 10 pf, 200 VDCW, temp coef -350 +500 PPM; sim to Matsushita ECV-1Z10P32.
C604 thru C606	19A116080P104	Polyester: 0.033 µf ±10%, 50 VDCW.
C607*	19B209351P2	Variable: 2.3 to 20 pf, 200 VDCW, temp coef -250 +700 PPM; sim to Matsushita ECV-1Z20P32.
	19B209351P1	Variable: 1.7 to 10 pf, 200 VDCW, temp coef -350 +500 PPM; sim to Matsushita ECV-1Z10P32.
C608*	19A116656P91J8	Ceramic, disc: 51 pf ±5%, 500 VDCW, temp coef -80 PPM. Deleted by REV B.
C608A*	19A116656P22J0	Ceramic, disc: 22 pf ±5%, 500 VDCW, temp coef 0 PPM. Added by REV B.
C608B*	19A116656P24J0	Ceramic, disc: 24 pf ±5%, 500 VDCW, temp coef 0 PPM. Added by REV B.
C609 and C610	19A116080P104	Polyester: 0.033 µf ±10%, 50 VDCW.
C611A*	19A116656P20J0	Ceramic, disc: 20 pf ±5%, 500 VDCW, temp coef 0 PPM.
	19A116656P13J0	Ceramic, disc: 13 pf ±5%, 500 VDCW, temp coef 0 PPM.
C611B*	19A116656P27J0	Ceramic, disc: 27 pf ±5%, 500 VDCW, temp coef 0 PPM.
	19A116656P15J0	Ceramic, disc: 15 pf ±5%, 500 VDCW, temp coef 0 PPM.
C612*	19B209351P2	Variable: 2.3 to 20 pf, 200 VDCW, temp coef -250 +700 PPM; sim to Matsushita ECV-1Z20P32.
	19B209351P1	Variable: 1.7 to 10 pf, 200 VDCW, temp coef -350 +500 PPM; sim to Matsushita ECV-1Z10P32.
C613A	19A116656P4J0	Ceramic, disc: 4 pf ±0.5 pf, 500 VDCW, temp coef 0 PPM.
C613B	19A116656P5J0	Ceramic, disc: 5 pf ±0.5 pf, 500 VDCW, temp coef 0 PPM.

SYMBOL	GE PART NO.	DESCRIPTION
C614	19A116655P19	Ceramic disc: 1000 pf ±20%, 1000 VDCW; sim to RMC Type JF Discap.
C615 thru C618	19A116080P104	Polyester: 0.033 µf ±10%, 50 VDCW.
C619 and C620	19A116656P91J2	Ceramic, disc: 91 pf ±5%, 500 VDCW, temp coef -220 PPM.
C621 and C622	19A116655P13	Ceramic disc: 470 pf ±20%, 1000 VDCW; sim to RMC Type JF Discap.
C623	19A116080P109	Polyester: 0.22 µf ±10%, 50 VDCW.
C624	7489162P25	Silver mica: 82 pf ±5%, 500 VDCW; sim to Electro Motive Type DM-15.
C625*	5496267P10	Tantalum: 22 µf ±20%, 15 VDCW; sim to Sprague Type 150D.
	5496267P111	Tantalum: 68 µf ±20%, 15 VDCW; sim to Sprague Type 150D.
C626	19A116080P106	Polyester: 0.068 µf ±10%, 50 VDCW.
C627	19A116080P108	Polyester: 0.15 µf ±10%, 50 VDCW.
C628	19A116080P109	Polyester: 0.22 µf ±10%, 50 VDCW.
C629	5496267P29	Tantalum: 0.68 µf ±20%, 35 VDCW; sim to Sprague Type 150D.
C630	5496267P5	Tantalum: 4.7 µf ±20%, 10 VDCW; sim to Sprague Type 150D.
C631	5496267P230	Tantalum: 0.82 µf ±10%, 35 VDCW; sim to Sprague Type 150D.
C632	5496267P18	Tantalum: 6.8 µf ±20%, 35 VDCW; sim to Sprague Type 150D.
C633*	19A116080P104	Polyester: 0.033 µf ±10%, 50 VDCW.
	19A116080P106	Polyester: 0.068 µf ±10%, 50 VDCW.
C634 and C635	5496267P226	Tantalum: 0.22 µf ±10%, 35 VDCW; sim to Sprague Type 150D.
C636	19A116655P19	Ceramic disc: 1000 pf ±20%, 1000 VDCW; sim to RMC Type JF Discap.
C637	19A116080P106	Polyester: 0.068 µf ±10%, 50 VDCW.
C638 and C639	19A116080P103	Polyester: 0.022 µf ±10%, 50 VDCW.
C640*	5496267P111	Tantalum: 68 µf ±20%, 15 VDCW; sim to Sprague Type 150D. Deleted in G1 by REV E, in G2 by REV F.
C641	19A116655P19	Ceramic disc: 1000 pf ±20%, 1000 VDCW; sim to RMC Type JF Discap.
C642	5496267P10	Tantalum: 22 µf ±20%, 15 VDCW; sim to Sprague Type 150D.
C643	19A116080P1	Polyester: 0.01 µf ±20%, 50 VDCW.
C644*	5496267P226	Tantalum: 0.22 µf ±10%, 35 VDCW; sim to Sprague Type 150D. Added by REV A.
C645*	19A116114P12	Ceramic: 3.3 pf ±5%, 100 VDCW; temp coef 0 PPM. Added by REV C.
C646*	5494481P111	Ceramic disc: 1000 pf ±20%, 1000 VDCW; sim to RMC Type JF Discap. Added to G1 by REV E and G2 by REV F.
C647*	19A116080P1	Polyester: 0.01 µf ±20%, 50 VDCW. Added to G1 by REV D and G2 by REV E.
----- DIODES AND RECTIFIERS -----		
CR601	4038056P1	Germanium.
CR602* and CR603*	19A116052P1	Silicon.
	19A115775P1	In REV B and earlier in G1, In REV C and earlier in G2; Silicon.

SYMBOL	GE PART NO.	DESCRIPTION
----- FILTERS -----		
FL601A	19B219573G3	Crystal freq: PAD A: 11,200000 KHz, PAD B: 11,196024 KHz.
FL601B	19B219574G3	Crystal freq: PAD A: 9400.300 KHz, PAD B: 9396.324 KHz.
FL602A	FL602B	(Part of FL601A).
FL603A	19B219573G1	Crystal freq: PAD A: 11,200000 KHz, PAD B: 11,200000 KHz.
FL603B	19B219574G1	Crystal freq: PAD A: 9400.300 KHz, PAD B: 9400.300 KHz.
FL604A	19B219604G1	Crystal freq: 11,200000 MHz.
FL604B	19B219604G2	Crystal freq: 9,400000 MHz.
----- JACKS AND RECEPTACLES -----		
J601	19B219374G1	Connector. Includes:
	19C317957P1	Shell.
	19A116651P1	Contact, electrical; sim to Malco X0-2864.
J604 and J605	19A116779P1	Contact, electrical; sim to Molex 08-54-0404.
J623* and J624*	19A116975P1	Contact, electrical.
	19A116428P5	Contact, electrical; sim to AMP 85486-6 (Strip Form).
----- INDUCTORS -----		
L601A*	19B209456P119	Coil, RF: 8.20 µh ±10%, 1.32 ohms DC res max; sim to Arco-Speer 155-8R2.
	19B209456P121	Coil, RF: 12 µh ±10%, 2.00 ohms DC res max; sim to Arco-Speer 155-120K.
L601B*	19B209456P120	Coil, RF: 10 µh ±10%, 1.62 ohms DC res max; sim to Arco-Speer 155-100K.
	19B209456P122	Coil, RF: 15 µh ±10%, 0.80 ohms DC res max; sim to Arco-Speer 155-150K.
L602A	19B209456P120	Coil, RF: 10 µh ±10%, 1.62 ohms DC res max; sim to Arco-Speer 155-100K.
L602B*	19B209456P121	Coil, RF: 12 µh ±10%, 2.00 ohms DC res max; sim to Arco-Speer 155-120K.
	19B209456P122	Coil, RF: 15 µh ±10%, 0.80 ohms DC res max; sim to Arco-Speer 155-150K.
L603A*	19B209456P118	Coil, RF: 6.80 µh ±10%, 1.02 ohms DC res max; sim to Arco-Speer 155-6R8.
	19B209456P120	Coil, RF: 10 µh ±10%, 1.62 ohms DC res max; sim to Arco-Speer 155-100K.
L603B*	19B209456P119	Coil, RF: 8.20 µh ±10%, 1.32 ohms DC res max; sim to Arco-Speer 155-8R2.
	19B209456P121	Coil, RF: 12 µh ±10%, 2.00 ohms DC res max; sim to Arco-Speer 155-120K.
L604	19B209456P125	Coil, RF: 27 µh ±10%, 1.19 ohms DC res max; sim to Arco-Speer 155-270K.
L605A	19C311181G13	Coil.
L605B	19C311181G14	Coil.
L606 and L607	7488079P18	Choke, RF: 15.0 µh ±10%, 1.20 ohms DC res max; sim to Jeffers 4421-9K.
L608	19B209420P125	Coil, RF: 10.0 µh ±10%, 3.10 ohms DC res max; sim to Jeffers 4446-4.

SYMBOL	GE PART NO.	DESCRIPTION
L609A*	19B209420P128	Coil, RF: 18.0 µh ±10%, 3.00 ohms DC res max; sim to Jeffers 1316-3. Added by REV B.
L609B*	19B209420P129	Coil, RF: 22.0 µh ±10%, 3.30 ohms DC res max; sim to Jeffers 1316-4. Added by REV B.
----- PLUGS -----		
P904	19B219594P1	Contact strip: 7 pins.
----- TRANSISTORS -----		
Q601 and Q602	19A116742P1	Silicon, NPN.
----- RESISTORS -----		
R601	3R152P391K	Composition: 390 ohms ±10%, 1/4 w.
R602	3R152P122K	Composition: 1200 ohms ±10%, 1/4 w.
R603	3R152P470K	Composition: 47 ohms ±10%, 1/4 w.
R604	3R152P331K	Composition: 330 ohms ±10%, 1/4 w.
R605	3R152P392K	Composition: 3900 ohms ±10%, 1/4 w.
R606	3R152P102K	Composition: 1000 ohms ±10%, 1/4 w.
R607	3R152P300K	Composition: 30 ohms ±10%, 1/4 w.
R608	3R152P332K	Composition: 3300 ohms ±10%, 1/4 w.
R609	3R152P433K	Composition: 43,000 ohms ±10%, 1/4 w.
R610	3R152P682K	Composition: 6800 ohms ±10%, 1/4 w.
R611A*	3R152P562J	Composition: 5600 ohms ±5%, 1/4 w.
	3R152P332K	Composition: 3300 ohms ±10%, 1/4 w.
R611B	3R152P103K	Composition: 10,000 ohms ±10%, 1/4 w.
R612A*	3R152P822J	Composition: 8200 ohms ±5%, 1/4 w.
	3R152P682K	Composition: 6800 ohms ±10%, 1/4 w.
R612B	3R152P133K	Composition: 13,000 ohms ±10%, 1/4 w.
R613	3R152P102K	Composition: 1000 ohms ±10%, 1/4 w.
R614	19B209358P107	Variable, carbon film: approx 75 to 25,000 ohms ±10%, 0.25 w; sim to CTS Type X-201.
R615	3R152P470K	Composition: 47 ohms ±10%, 1/4 w.
R616	3R152P303J	Composition: 30,000 ohms ±5%, 1/4 w.
R617 and R618	19B209202P5	Wirewound: 0.39 ohms ±5%, 2 w; sim to IRC Type BWH.
R619	3R152P220K	Composition: 22 ohms ±10%, 1/4 w.
R620	3R151P681J	Composition: 680 ohms ±5%, 1/8 w.
R621*	3R151P273J	Composition: 27,000 ohms ±5%, 1/8 w.
	3R151P153J	Composition: 15,000 ohms ±5%, 1/8 w.
R622	3R152P302J	Composition: 3000 ohms ±5%, 1/4 w.
----- THERMISTORS -----		
RT601	5490828P38	Thermistor: 1400 ohms ±5%, color code green and white; sim to Global Type 492H.
----- TRANSFORMERS -----		
T601	19A116747P1	Audio freq: 500 to 4000 Hz, Pri: 0.345 ohm ±15%, Sec 1: 0.36 ohms ±10%, Sec 2: 0.685 ohms ±15%.
----- TEST POINTS -----		
TP601*	N503P304C6	Cotter pin. Added by REV B.
----- INTEGRATED CIRCUITS -----		
U601	19A116796P1	Linear, Wide Band Amplifier/Discriminator; sim to CA 3014.

SYMBOL	GE PART NO.	DESCRIPTION
U602	19A116797P1	Linear, Limiter/Audio Pre-Amp; sim to CA3042.
U603	19D416606G1	Squelch Hybrid, integrated circuit.
U604	19D416573G1	Audio Hybrid.
MECHANICAL PARTS (SEE RC-2439)		
1	19B219727G1	Shield. (Located on bottom of circuit board under U602).
2	19B219557P1	Heat sink. (For Q601 and Q602).
3	19A116023P3	Insulator, plate. (Used with Q601 and Q602).
4	19A116022P1	Bushing. (Used with Q601 and Q602).
5	4029846P1	Nut, hex, self-locking: No. 4-40. (Used with Q601 and Q602).
6	19A116417P4	Bumper, plastic. (Located at T601).
7	19C320166P1	Shield. (Located around FL601, and FL602).
8	19B219571G1	Shield. (Located on bottom of circuit board under FL601 and FL602).
9	4035306P59	Washer, fiber. (Used with FL601-FL604).
10	19A116428P4	Ground tab: sim to AMP 86031-1 (Strip Form). (Used with shields on bottom of circuit board).
11	19B219470P3	Shield. (Located by J623 and J624).
12	19B219555P1	Cover. (Located over U602 and FL604).
13	19B219554G1	Can. (Located around U602 and FL604).

PRODUCTION CHANGES

Changes in the equipment to improve performance or to simplify circuits are identified by a "Revision Letter", which is stamped after the model number of the unit. The revision stamped on the unit includes all previous revisions. Refer to the Parts List for descriptions of parts affected by these revisions.

IF Audio and Squelch Board (19D41660G1 and G2)

- REV. A - Incorporated into initial shipment.
- REV. B - To improve IF frequency response. Changed L601, L602, L603, and added L609. Changed C601, C602, C603, C607, C608, C611, and C612. Added TP601.

IF Audio and Squelch Board (19D41660G2)

- REV. C - To increase audio output and reduce distortion. Added C645.

IF Audio and Squelch Board (19D41660G1)

- REV. C - To improve sensitivity and squelch operation. Changed R621, R611A, R612A, CR602 and CR603. Added C645.

IF Audio and Squelch Board (19D41660G2)

- REV. D - To improve sensitivity and squelch operation. Changed R621, CR602 and CR603.

IF Audio and Squelch Board 19D41660G1

- REV. D - IF Audio and Squelch Board 19D41660G1
- REV. E - IF Audio and Squelch Board 19D41660G2

IF Audio and Squelch Board (19D41660G1)

- REV. E - IF Audio and Squelch Board (19D41660G1)
 - REV. F - IF Audio and Squelch Board (19D41660G2)
- To provide RF decoupling of the RX-PA input lead. Added C646, changed C629 and deleted C640.

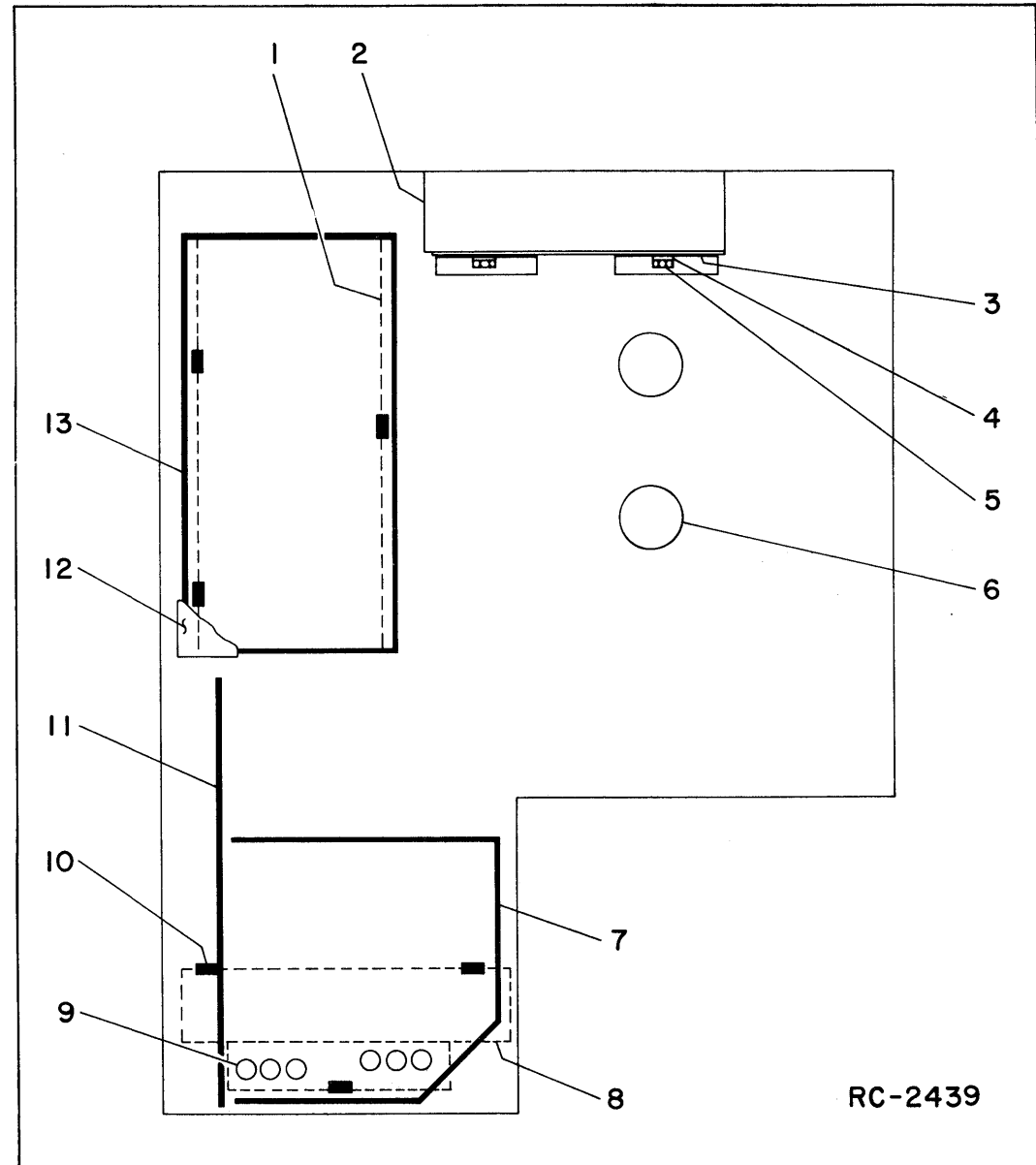

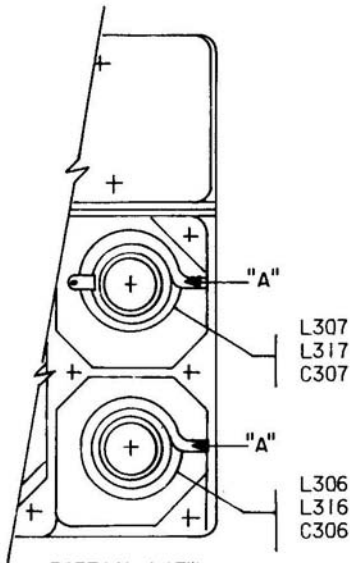

PARTIAL VIEW
R.F. CKT PL19D416693

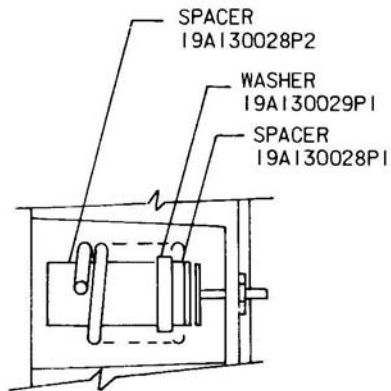

VIEW AT "A"
(PARTIAL)
(TYP TWO PLACES)

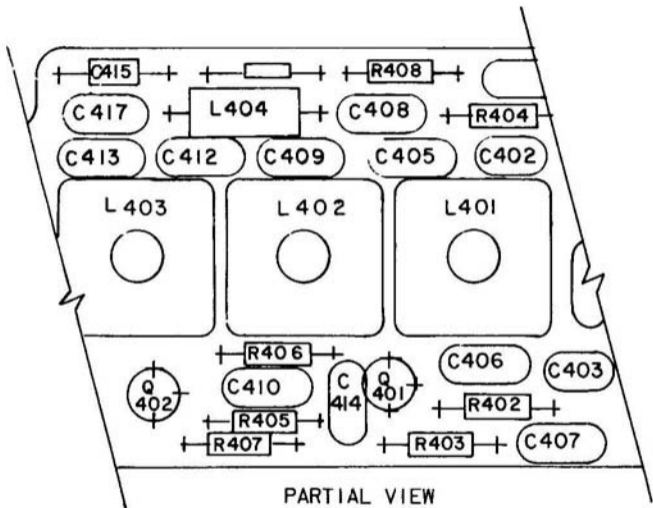

PARTIAL VIEW

OSC/MULT BD. PL19D416610

LABEL
19A130206PI
(SEE STEP 5,
MODIFICATION
INSTRUCTIONS)

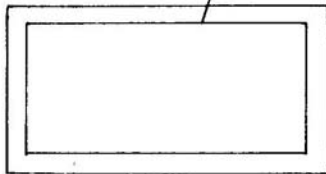

IFAS BD. PL19D416606

MODIFICATION INSTRUCTIONS FOR HIGH BAND HIGH SIDE INJECTION.

1. ON OSC/MULT BD'S 19D416610G1 & G3 (LOW SPLIT) REPLACE C405 WITH C2301 (12pf), REPLACE C409 WITH C2302 (4pf) AND REPLACE C413 WITH C2303 (4pf)
DISCARD ITEMS C2304, C2305, & C2306.
ON OSC/MULT BD'S 19D416610G2 & G4 (HIGH SPLIT) REPLACE C405 WITH C2304 (10pf), REPLACE C409 WITH C2305 (2.2pf) AND REPLACE C413 WITH C2306 (2.2pf)
DISCARD ITEMS C2301, C2302, & C2303.
SOLDER ALL ELECTRICAL CONNECTIONS.
C2301 THRU C2306 ARE PART OF MOD KIT 19A130045G1.
2. MODIFY RF. CKT ASM PL19D416693 BY ADDING 19A130028P1, SPACER, 19A130029P1 WASHER, AND 19A130028P2 SPACER AS SHOWN TO L306 & L307 (LOW SPLIT) OR L316, & L317 (HIGH SPLIT). SLIDE SPACERS, & WASHER ON CERAMIC POST FROM TOP IN ORDER SHOWN. THESE ITEMS ARE PART OF MOD KIT PL19A130045G1.
3. IN APPLICATION OF THIS KIT THE CRYSTAL OSCILLATOR FREQUENCY MUST BE CHANGED PER THE FOLLOWING FORMULA:
$$F_x = \frac{F_o + 11.2}{9}$$
4. MARK ALL OSC/MULT. BD'S (19D416610) WITH A BLUE COLOR DOT IN THE AREA OF THE PL DRAWING NO. PER 19A115740P1.
MARK ALL RECEIVER CASTINGS WITH A BLUE COLOR DOT IN THE AREA OF THE PL DRAWING NO. PER 19A115740P1.
5. APPLY LABEL (19A130206P1) TO DISCRIMINATOR COVER ON IFAS BD.

MODIFICATION INSTRUCTIONS

HIGH SIDE FREQUENCY INJECTION KIT